



**LED Display**  
**Product Data Sheet**  
LTM-8522E

Spec No. :DS-30-98-325  
Effective Date: 01/20/2023  
Revision: A

**LITE-ON DCC**

**RELEASE**

**BNS-OD-FC001/A4**

**LED DISPLAY  
LTM-8522E**

**LED DISPLAY**

LTM-8522E

<u>Rev</u>	<u>Description</u>	<u>By</u>	<u>Date</u> <u>DD/MM/YYYY</u>
01	NPPR Original Spec	Amanda Lin	06/23/2000
<b>Above data for PD and Customer tracking only</b>			
-	NPPR Original Spec	Amanda Lin	06/23/2000
A	1.Add AllnGaP dice in description at page 2 2.Update note 2 of Electrical/Optical Characteristics at page 5 3.Correct typical Electrical/Optical Characteristics Curves at page 6	William Lin	01/18/2023

## LED DISPLAY LTM-8522E

### 1. Description

The LTM-8522E is a 0.56-inch (14.22-mm) numeric display modules, and a built-in M5450 MOS integrated circuits. The integrated circuit contains serial data input, 35 bits shift register, 34 LED driver output and a brightness control. This device utilizes red orange LED chips, which are made from GaAsP on a transparent GaP substrate / AlInGaP on a non-transparent GaAs substrate and has an orange face and orange segments. The MOS integrated circuits are produced with N-channel silicon gate technology.

#### 1.1 Features

- \* 0.56-INCH (14.22-mm) DIGIT HEIGHT.
- \* WIDE SUPPLY VOLTAGE OPERATION.
- \* SERIAL DATA INPUT.
- \* CONSTANT CURRENT DRIVERS.
- \* CONTINUOUS BRIGHTNESS CONTROL.
- \* SOLID STATE RELIABILITY-LONG OPERATION LIFE.
- \* WIDE VIEWING ANGLE.
- \* TTL COMPATIBLE.
- \* LEAD-FREE PACKAGE (ACCORDING TO ROHS).

#### 1.2 Device

Part No	Description
Red Orange	3 Digit
LTM-8522E	Rt. Hand Decimal

## LED DISPLAY LTM-8522E

### 2. Package Dimensions

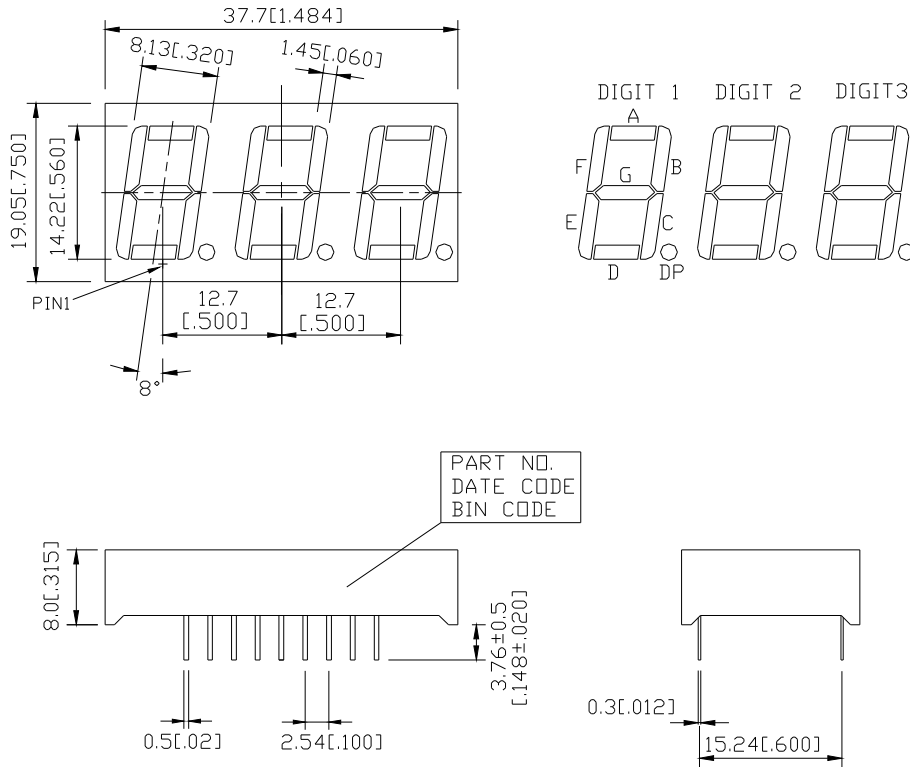

**Note:**

1. All dimensions are in millimeters. Tolerances are  $\pm 0.25$  mm (0.01") unless otherwise noted.

**LED DISPLAY  
LTM-8522E**

**3. Pin Connection**

No.	CONNECTION
1	VSS
2	VLED
3	VLED
4	BIT 25 OUTPUT
5	BIT 26 OUTPUT
6	BIT 27 OUTPUT
7	BIT 28 OUTPUT
8	BIT 29 OUTPUT
9	BIT 30 OUTPUT
10	BIT 31 OUTPUT
11	BIT 32 OUTPUT
12	BIT 33 OUTPUT
13	BIT 34 OUTPUT
14	DATA ENABLE
15	DATA INPUT
16	CLOCK INPUT
17	VDD
18	BRT. CONTROL

## LED DISPLAY LTM-8522E

### 4. Rating and Characteristics

#### 4.1. Absolute Maximum Rating at Ta=25°C

PARAMETER	Symbol	Min.	Max.	UNIT
Supply Voltage *1	VDD	-0.3	12	V
Input Voltage	VI	-0.3	12	V
Off State Output Voltage	VO(off)		12	V
LED Supply Voltage	VLED	2.8	3.5	V
Power Dissipation of IC *2	PD(IC)		335	mW
Supply Current	IDD		8.5	mA
Operating Temperature Range	Top	-20	+60	°C
Storage Temperature Range	Tstg	-20	+60	°C
Solder Temperature 1/16 inch Below Seating Plane for 3 Seconds at 260°C				

#### 4.2. RECOMMENDED OPERATING CONDITION AT TA=25°C

Parameter	Symbol	Min.	Typ.	Max.	Unit	Test Condition
Supply Voltage	VDD	4.75		11	V	
Input Voltage						
Logical "0" Level		-0.3		0.8	V	±10µA Input Bias
Logical "1" Level	VI	2.2		VDD	V	4.75V < VDD < 5.25V
Logical "1" Level		VDD -2		VDD	V	VDD > 5.25V
Brightness Input Current	IB	0		0.75	mA	
Brightness Input Voltage	VB	3		4.3	V	Input Current=750µA
Off State Voltage	VO(off)			11	V	
Output Sink Current						
Segment Off				10	µA	IB=0 µA
Segment On			3		mA	IB=100 µA
			6		mA	IB=200 µA
Input Clock Frequency	FCLOCK	0		0.5	MHZ	
Output Matching	IO			±20	%	

**Note:**

- Luminous intensity is measured with a light sensor and filter combination that approximates the CIE (Commission International De L'Eclariage) eye-response curve.

## LED DISPLAY LTM-8522E

### 4.3. Electrical / Optical Characteristics at Ta=25°C

Parameter	Symbol	MIN.	TYP.	MAX.	Unit	Test Condition
Average Luminous Intensity	IV	800	2400		μcd	IB=0.4mA
Peak Emission Wavelength	λp		630		nm	IB=0.4mA
Spectral Line Half-Width	Δλ		40		Nm	IB=0.4mA
Dominant Wavelength	λd		621		nm	IF=20mA
Luminous Intensity Matching Ratio	IV-m			2:1		IB=0.4mA

**Note:**

1. Luminous intensity is measured with a light sensor and filter combination that approximates the CIE (Commission International De L'Eclairage) eye-response curve.
2. Reverse voltage is only for IR test, it cannot continue to operate this situation.

## LED DISPLAY LTM-8522E

### 5. Rating and Characteristics

Serial data transfer from the data source to the display driver is accomplished with 2 signals serial data and clock. Using a format of a leading “1” followed by the 35 data bits allow data transfer without an additional load signal. The 35 data bits are latched after the 36th bit is completed, thus providing non multiplexed, direct drive to the display. Outputs change only if the serial data bits differ from the previous time.

Brightness of display is determined by control the output current of LED display. A 1nF capacitor should be connected to brightness control, Pin 7 to prevent possible oscillations. The output current is typically 25 times greater than the current into Pin 7 which is set by an external variable resistor. There is an internal limiting resistor of 400 Ω nominal value.

Figure 1 shows the input data format. A start bit of logical “1” proceed the 35 bits of data. At the 36th clock, a LOAD signal is generated synchronously with the high state of the clock, which loads the 35 bits of the shift registers into the latches. At the low state of the clock a RESET signal is generated which clears all the shift registers for the next set of data. The shift registers are static master-slave configuration. There is no clear for master portion of the first register, thus allowing continuous operation.

There must be a complete set of 36 clocks or the shift registers won't clear. When power is first applied to the chip, an internal power ON, a reset signal is generated which reset all registers and all latches. The START bit and first clock return the chip on its normal operation. Bit 1 is the first following the start bit and it will appear on the segment A of the digit 1. A logical “1” at the input will turn on the appropriate LED. Figure 2 shows the timing relationship between data, clock, and DATA ENABLE. A max. clock frequency of 0.5 MHz is assumed.

#### 5.1. FIGURE 1. INTERNAL BLOCK DIAGRAM

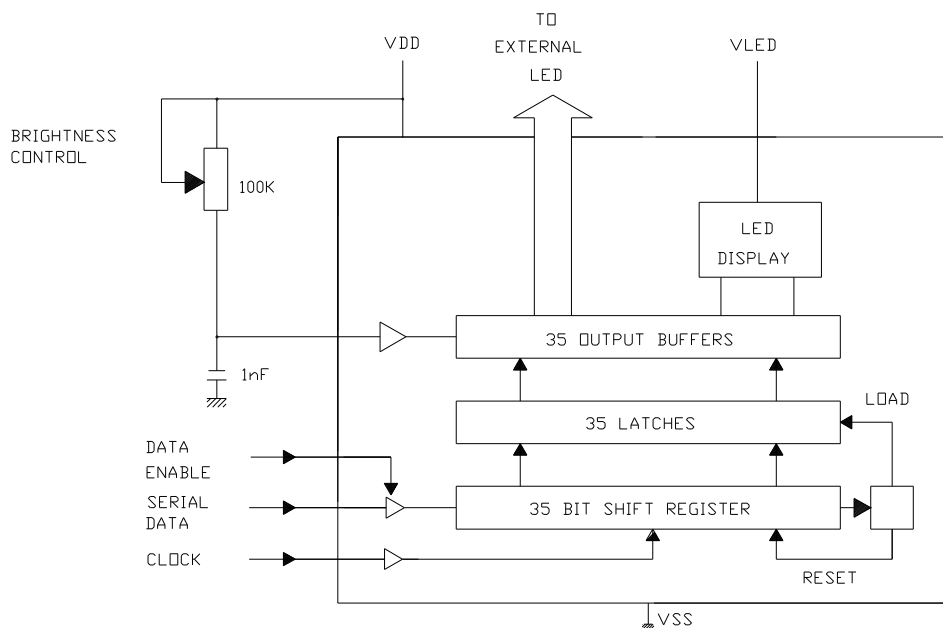



**LED DISPLAY  
LTM-8522E**

**5.2. FIGURE 2. INPUT DATA FORMAT**

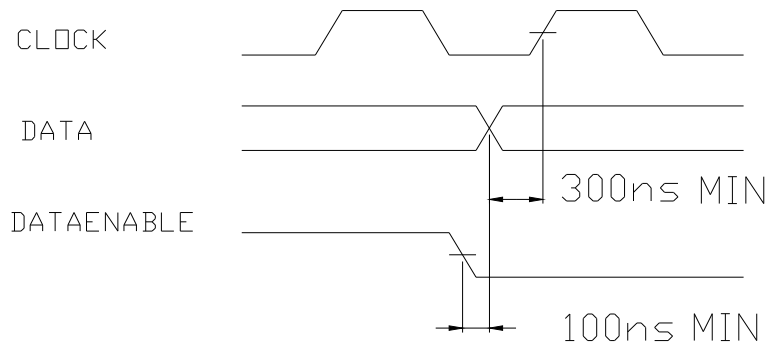

**5.3. FIGURE 3. TIMING RELATIONSHIP**

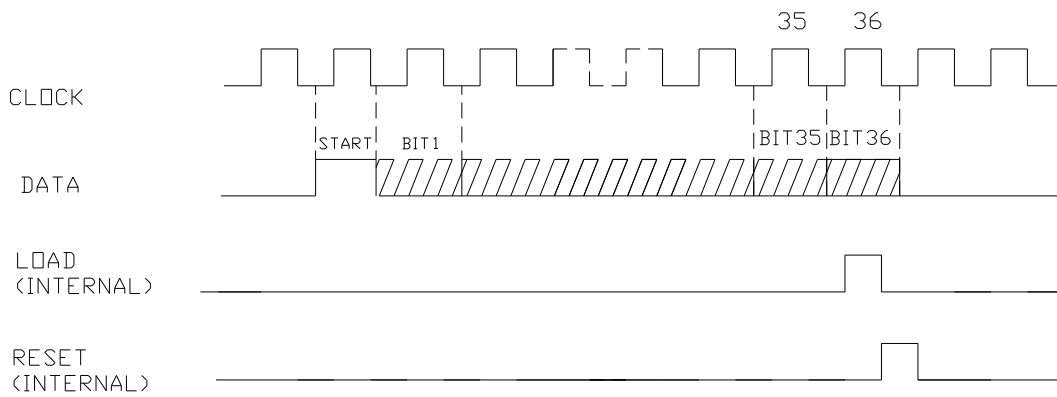

**6. TABLE 1 SERIAL DATA INPUT SEQUENCE**

**LED DISPLAY  
LTM-8522E**

BIT	LTM-8522	
	DIGIT	SEGMENT
1	1	A
2	1	B
3	1	C
4	1	D
5	1	E
6	1	F
7	1	G
8	1	D.P.
9	2	A
10	2	B
11	2	C
12	2	D
13	2	E
14	2	F
15	2	G
16	2	D.P.
17	3	A
18	3	B
19	3	C
20	3	D
21	3	E
22	3	F
23	3	G
24	3	D.P.
25		PIN 4
26		PIN 5
27		PIN 6
28		PIN 7
29		PIN 8
30		PIN 9
31		PIN 10
32		PIN 11
33		PIN 12
34		PIN 13

**7. TYPICAL APPLICATION**

**LED DISPLAY  
LTM-8522E**

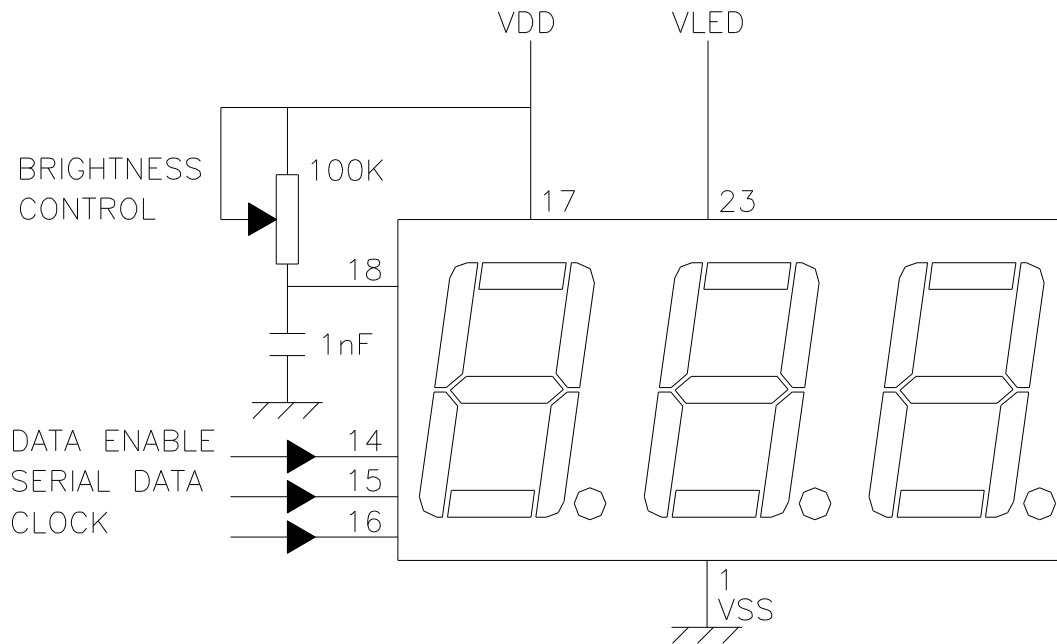

**8. CAUTIONS**

## LED DISPLAY LTM-8522E

### 8.1. Application

- The display described here are intended to be used for ordinary electronic equipment (such as office equipment, communication equipment and household applications). Consult Liteon's Sales in advance for information on applications in which exceptional reliability is required, particularly when the failure or malfunction of the display may directly jeopardize life or health (such as in aviation, transportation, traffic control equipment, medical and life support systems and safety devices).
- When using this LED display, please make sure absolute maximum ratings and the instructions for using outlined in these specification sheets. LITEON will not be responsible for any damage resulting from use of the product which does not comply with the absolute maximum ratings and the instructions included in these specification sheets.
- Excess driving current and/or operating temperature higher than recommended conditions may result in severe light degradation or premature failure.
- The driving circuit should be designed to protect the LEDs inside the display against reverse voltages and transient voltage spikes when the circuit is powered up or shut down.
- Constant current driving is recommended to ensure consistent performance.
- Circuit design must cater to the whole range of forward voltage (VF) of the LEDs inside the display to ensure the intended drive current can always be achieved.
- The safe operating current should be chosen after considering the maximum ambient temperature of the operating environment.
- Reverse bias should be avoided, as it could cause metal migration, leading to an increase in leakage current or causing a short circuit.
- Avoid rapid changes in ambient temperatures, especially in high-humidity environments, because they cause condensation on the LED/LED display.
- Do not use unsuitable tool or assembly method to have abnormal force on display body cause damage.
- Printing/pattern film is using pressure sensitive glue to stick on LED display surface, not recommend to let LED display pattern film side close contact with front panel/cover, since the printing/pattern film may shift or moved from original position by external force.
- Recommend choose same BIN LED display while you assemble 2 or above 2 pcs LED display for one set application to avoid hue uneven problems.

### 8.2. Storage conditions

## LED DISPLAY LTM-8522E

- LED Display standard storage condition.
  - Product in the original packaging material state is recommended storage conditions.
  - Temperature Condition: 5°C~30°C
  - Humidity Condition: Below 60%RH

If the storage conditions do not meet specification standards, the LED display pins may become oxidized requiring re-plating and re-sorting before use. Suggest customers consume display as soon as possible, and avoid long-term storage of large inventories.
  
- LED SMD Display standard storage condition
  - When the package is in factory original sealed bag.
  - Temperature Condition: 5°C~30°C
  - Humidity Condition: Below 60%RH
  - When the package is opened and not in factory original sealed bag.
  - Temperature Condition: 5°C~30°C
  - Humidity Condition: Below 60%RH
  - Storage time: Within 168Hr (MSL as level 3)

If the storage conditions do not meet specification standards, the LED display pins or soldering pads may become oxidized requiring re-plating and re-sorting before use. Suggest customers consume display as soon as possible, and avoid long-term storage of large inventories.
  
- Recommend to baking the LEDs at 60 °C for 24hrs before soldering process if the LED SMD Display were unpacked more than 168hrs.
  
- The Displays recommend to used within 12 months from shipping date.
  
- The Displays should not be exposed to an environment where high level of moisture or corrosive gases are present.
  
- LED display pins and soldering pads are plated with gold, tin, or other metals. Under long-term exposure to open air, the exposed pins and pads may become oxidized causing poor solderability. Therefore opened but unused parts must be stored in sealed containers or controlled environment. Suggest to store unused SMD Display parts in the original moisture barrier bag and sealed.
  
- Moisture control for components already mounted on PCB
  - If the PCB will not undergo additional reflow soldering or high-temperature processes, then no special treatment is required for the mounted moisture-sensitive SMD components. If the PCB will undergo multiple reflow soldering or other high-temperature processes, including rework, then the SMD component's cumulative exposure time until the final high-temperature process must be controlled to within the specified time limit.

## LED DISPLAY LTM-8522E

### 8.3. Cleaning

- Do not use unspecified chemical liquid to clean display they could harm the package.

### 8.4. ESD (Electrostatic Discharge)

Static Electricity or power surge will damage LED inside the display.

Suggestions to prevent ESD damage:

- Use of a conductive wrist band or anti-electrostatic glove when handling these LED displays.
- All devices, equipment, and machinery, working tables, storage racks, etc. must be properly grounded.
- Use ion blower to neutralize the static charge which might have built up on surface of the LED display plastic as a result of friction between LED display during storage and handling.

### 8.5. Terms and conditions for the usage of this document

- Keep same appearance and performance the contents of the product may be modified for productivity and reliability improvement without prior notice.
- The information included in this document reflects representative usage scenarios and is intended for technical reference only.
- When using the products referenced in this document, please make sure the product is being operated within the environmental and electrical limits specified in the datasheet. If customer usage exceeds the specified limits, LITEON will not be responsible for any subsequent issues.
- Excess driving current and/or operating temperature higher than recommended conditions may result in severe light degradation or premature failure.
- The information in this document applies to typical usage in consumer electronics applications. If customer's application has special reliability requirements or have life-threatening liabilities, such as automotive or medical usage, please consult with LITEON representative for further assistance.
- The contents and information of this document may not be reproduced or re-transmitted without permission by LITEON.
- When any special process such as potting is required for LED display assembly, please consult with LITEON representative before proceeding.
- Over-current-proof  
Customer must apply resistors for protection, otherwise slight voltage shift will cause big current change (Burn out will happen).