



IR Emitter and Detector Product Data Sheet LTR-5888DHP1

Spec No.: DS-50-96-0056

Effective Date: 05/20/2000

Revision: A

LITE-ON DCC

RELEASE

BNS-OD-FC001/A4

FEATURES

- * WIDE RANGE OF COLLECTOR CURRENT
- * HIGH SENSITIVITY
- * FAST SWITCHING TIME
- * THE LTR-5888DHP1 IS A SPECIAL DARK GREEN PLASTIC PACKAGE THAT CUT THE VISIBLE FOR THE DETECTORS OF INFRARED APPLICATIONS

PACKAGE DIMENSIONS

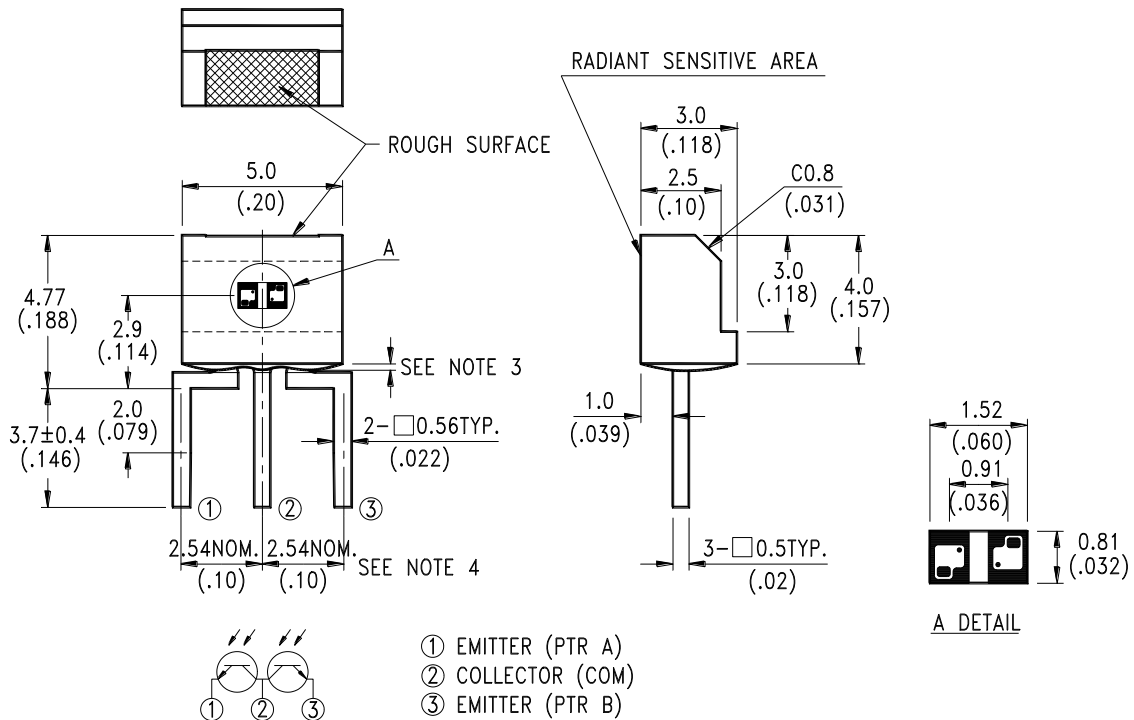

NOTES:

1. All dimensions are in millimeters (inches).
2. Tolerance is ±0.25mm(.010") unless otherwise noted.
3. Protruded resin under flange is 1.5mm(.059") max.
4. Lead spacing is measured where the leads emerge from the package.
5. Specifications are subject to change without notice.



ABSOLUTE MAXIMUM RATINGS AT TA=25°C

PARAMETER	MAXIMUM RATING	UNIT
Power Dissipation	100	mW
Collector-Emitter Voltage	30	V
Emitter-Collector Voltage	5	V
Operating Temperature Range	-40°C to + 85°C	
Storage Temperature Range	-55°C to + 100°C	
Lead Soldering Temperature [1.6mm(.063") From Body]	260°C for 5 Seconds	



ELECTRICAL / OPTICAL CHARACTERISTICS AT TA=25°C

PARAMETER	SYMBOL	MIN.	TYP.	MAX.	UNIT	TEST CONDITION	BIN NO.	Color Marking
Collector-Emitter Breakdown Voltage	$V_{(BR)CEO}$	30			V	$I_C = 1mA$ $E_e = 0mW/cm^2$		
Emitter-Collector Breakdown Voltage	$V_{(BR)ECO}$	5			V	$I_E = 100 \mu A$ $E_e = 0mW/cm^2$		
Collector Emitter Saturation Voltage	$V_{CE(SAT)}$		0.1	0.4	V	$I_C = 100 \mu A$ $E_e = 1mW/cm^2$		
Rise Time	T_r		15		μs	$V_{CC} = 5V$ $I_C = 1mA$ $R_L = 1K\Omega$		
Fall Time	T_f		18		μs			
Collector Dark Current	I_{CEO}		0.1	100	nA	$V_{CE} = 10V$ $E_e = 0mW/cm^2$		
Collector Current Ratio Of 2 Phototransistor	R	0.8	1.0	1.25		$I_{C(ON)(a)} / I_{C(ON)(b)}$		
On State Collector Current Range Setting of LITE-ON Production $[I_{C(ON)(a)} + I_{C(ON)(b)}] / 2$	$I_{C(ON)}$	0.20		0.26	mA	$V_{CE} = 5V$ $E_e = 1mW/cm^2$	BIN A	Red
		0.26		0.32			BIN B	Black
		0.32		0.38			BIN C	Green
		0.38		0.46			BIN D	Blue
		0.46		0.52			BIN E	White
		0.52		0.58			BIN F	Purple
		0.58		0.64			BIN G	Yellow
		0.64		0.70			BIN H	Orange
On State Collector Current Range $[I_{C(ON)(a)} + I_{C(ON)(b)}] / 2$	$I_{C(ON)}$	0.16		0.31	mA	$V_{CE} = 5V$ $E_e = 1mW/cm^2$	BIN A	Red
		0.20		0.38			BIN B	Black
		0.26		0.46			BIN C	Green
		0.30		0.55			BIN D	Blue
		0.36		0.62			BIN E	White
		0.42		0.70			BIN F	Purple
		0.46		0.76			BIN G	Yellow
		0.51		0.84			BIN H	Orange

TYPICAL ELECTRICAL / OPTICAL CHARACTERISTICS CURVES

(25°C Ambient Temperature Unless Otherwise Noted)

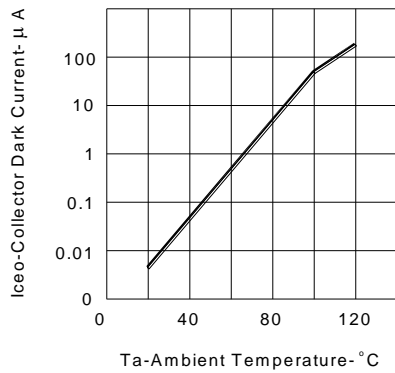

FIG.1 COLLECTOR DARK CURRENT VS AMBIENT TEMPERATURE

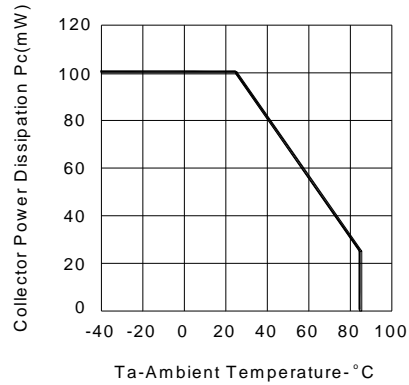

FIG.2 COLLECTOR POWER DISSIPATION VS AMBIENT TEMPERATURE

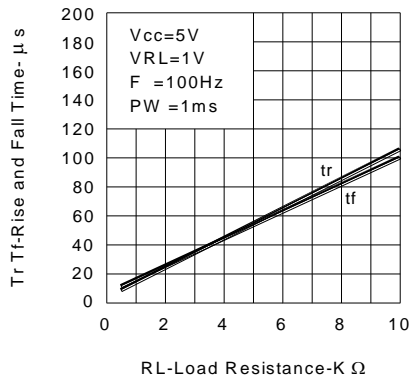

FIG.3 RISE AND FALL TIME VS LOAD RESISTANCE

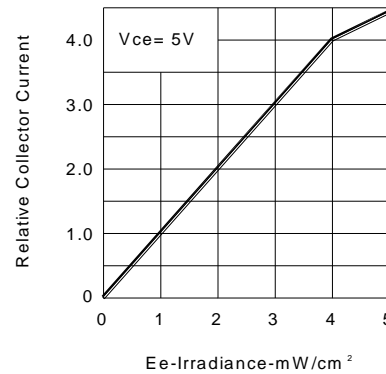

FIG.4 RELATIVE COLLECTOR CURRENT VS IRRADIANCE