



# IR Emitter and Detector Product Data Sheet

LTE-3277

Spec No.: DS-50-99-0007

Effective Date: 02/15/2005

Revision: B

**LITE-ON DCC**

**RELEASE**

BNS-OD-FC001/A4

## FEATURES

- \* HIGH SPEED
- \* HIGH POWER
- \* AVAILABLE FOR PULSE OPERATING
- \* CLEAR TRANSPARENT COLOR PACKAGE

## PACKAGE DIMENSIONS

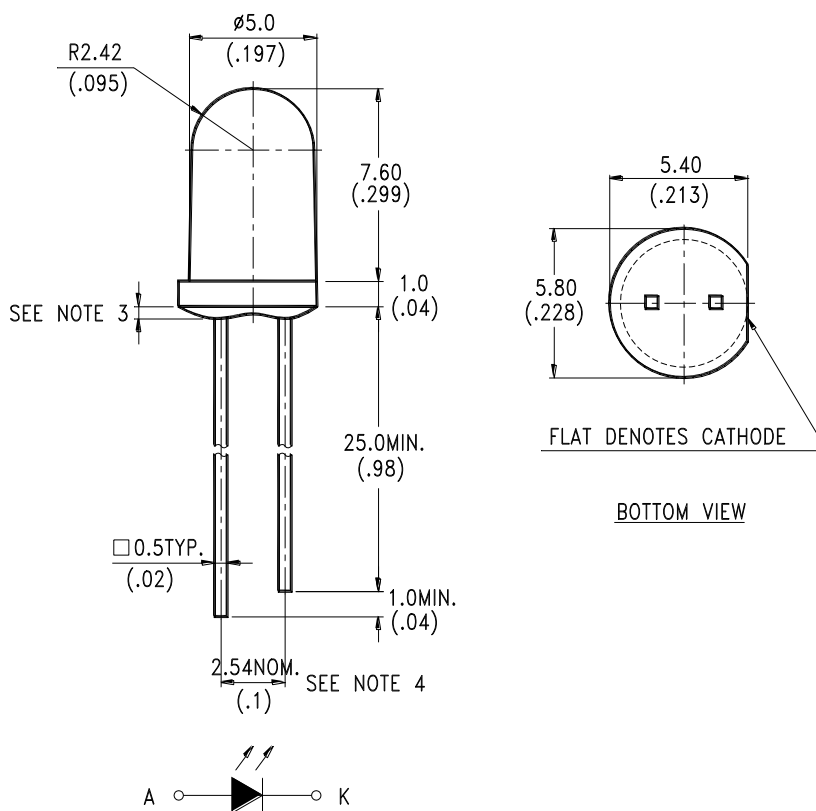

### NOTES:

1. All dimensions are in millimeters (inches).
2. Tolerance is  $\pm 0.25\text{mm}$  (.010") unless otherwise noted.
3. Protruded resin under flange is 1.5mm (.059") max.
4. Lead spacing is measured where the leads emerge from the package.
5. Specifications are subject to change without notice.



# LITE-ON TECHNOLOGY CORPORATION

Property of Lite-On Only

## ABSOLUTE MAXIMUM RATINGS AT TA=25°C

| PARAMETER  | MAXIMUM RATING      | UNIT |
|--|---------------------|------|
| Power Dissipation                                      | 120                 | mW   |
| Peak Forward Current (300pps, 10 $\mu$ s pulse)        | 1                   | A    |
| Continuous Forward Current                             | 100                 | mA   |
| Reverse Voltage  | 5                   | V    |
| Operating Temperature Range                            | -40°C to + 85°C     |      |
| Storage Temperature Range                              | -40°C to + 85°C     |      |
| Lead Soldering Temperature<br>[1.6mm(.063") From Body] | 260°C for 6 Seconds |      |

## ELECTRICAL / OPTICAL CHARACTERISTICS AT TA=25°C

| PARAMETER                 | SYMBOL           | MIN. | TYP. | MAX. | UNIT    | TEST CONDITION          |
|---------------------------|------------------|------|------|------|---------|-------------------------|
| Radiant Intensity         | $I_E$            | 20   | 36   | -    | mW/sr   | $I_F = 20mA$            |
| Peak Emission Wavelength  | $\lambda_P$      | -    | 865  | -    | nm      | $I_F = 20mA$            |
| Spectral Line Half-Width  | $\Delta \lambda$ | -    | 25   | -    | nm      | $I_F = 20mA$            |
| Forward Voltage           | $V_F$            | -    | 1.45 | 1.65 | V       | $I_F = 20mA$            |
| Forward Voltage           | $\Delta V_F$     | -    | -    | 0.4  | V       | $V_F@ 50mA - V_F@ 20mA$ |
| Reverse Current           | $I_R$            | -    | -    | 10   | $\mu A$ | $V_R = 5V$              |
| Reverse Voltage           | $V_R$            | 5    | -    | -    | V       | $I_R = 100 \mu A$       |
| Viewing Angle (See FIG.6) | $2\theta_{1/2}$  | 25   | 30   | -    | deg.    | $I_F = 20mA$            |
| Dice Center               | -                | 0    | -    | 0.12 | mm      | -                       |

## TYPICAL ELECTRICAL / OPTICAL CHARACTERISTICS CURVES

(25°C Ambient Temperature Unless Otherwise Noted)

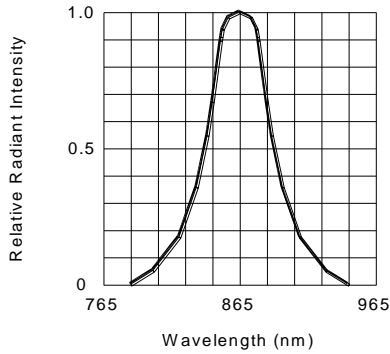

FIG.1 SPECTRAL DISTRIBUTION

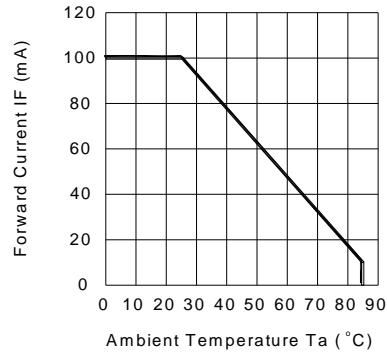

FIG.2 FORWARD CURRENT VS. AMBIENT TEMPERATURE

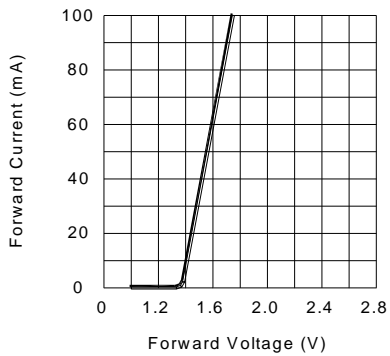

FIG.3 FORWARD CURRENT VS. FORWARD VOLTAGE

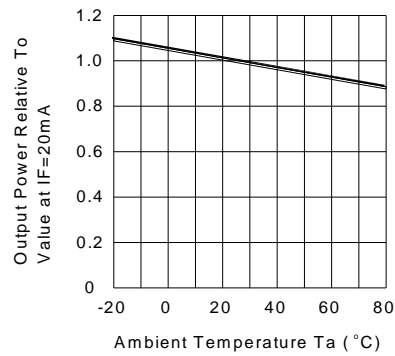

FIG.4 RELATIVE RADIANT INTENSITY VS. AMBIENT TEMPERATURE

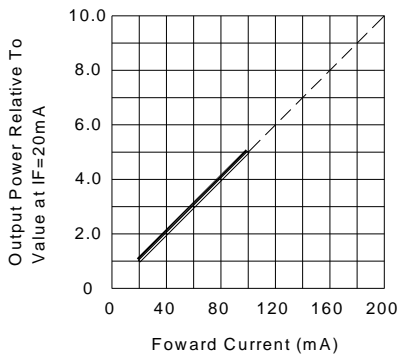

FIG.5 RELATIVE RADIANT INTENSITY VS. FORWARD CURRENT

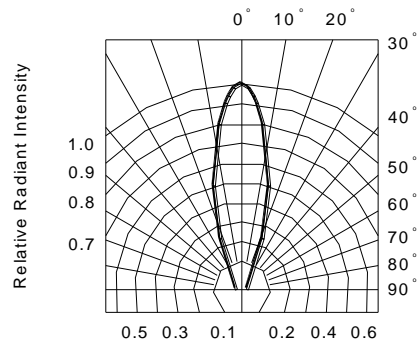

FIG.6 RADIATION DIAGRAM