



# Through Hole Lamp Product Data Sheet LTL30EKDKGK

Spec No.: DS20-2012-0114

Effective Date: 07/21/2012

Revision: -

**LITE-ON DCC**

**RELEASE**

BNS-OD-FC001/A4

Property of Lite-On Only

## Features

- \* Lead (Pb) Free - RoHS compliant
- \* Red and Green chips are matched for uniform light output.
- \* T-1 3/4 type package.
- \* Long life-solid state reliability.
- \* Low power consumption.

## Package Dimensions

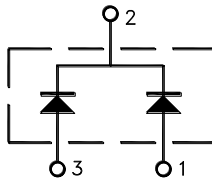
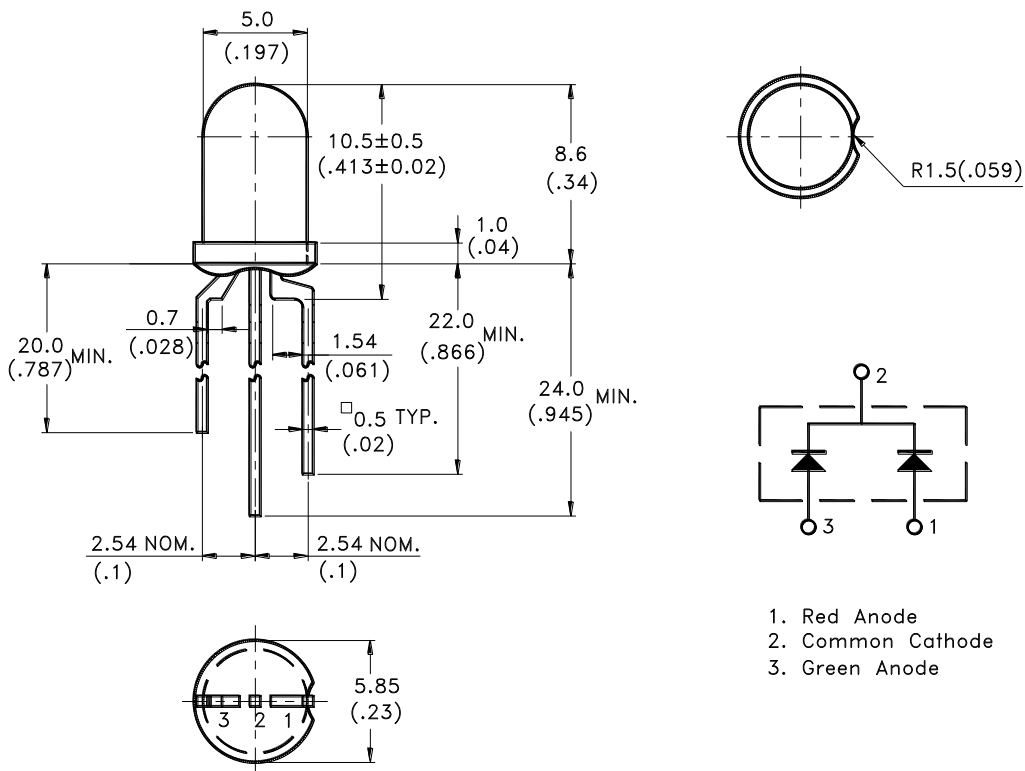

1. Red Anode
2. Common Cathode
3. Green Anode

Part No.	Lens	Source Color
LTL30EKDKGK	Water Clear	AllnGaP Red / AllnGaP Green

### Notes:

1. All dimensions are in millimeters (inches).
2. Tolerance is ±0.25mm(.010") unless otherwise noted.
3. Protruded resin under flange is 1.0mm(.04") max.
4. Lead spacing is measured where the leads emerge from the package.
5. Specification is subject to change without notice.

**Absolute Maximum Ratings at T<sub>A</sub>=25°C**

Parameter	Red	Green	Unit
Power Dissipation	75	75	mW
Peak Forward Current (1/10 Duty Cycle, 0.1ms Pulse Width)	90	90	mA
Continuous Forward Current	30	30	mA
Derating Linear From 50°C	0.57	0.57	mA/°C
Operating Temperature Range	-40°C to + 85°C		
Storage Temperature Range	-55°C to + 100°C		
Lead Soldering Temperature [2.0 mm(.08") From Body]	260°C for 5 Seconds Max		

## Electrical Optical Characteristics at TA=25°C

Parameter	Symbol	Color	Min.	Typ.	Max.	Unit	Test Condition
Luminous Intensity	I <sub>v</sub>	Red Green	520 520	880 880	1500 1500	mcd	I <sub>F</sub> = 20mA I <sub>F</sub> = 20mA Note 1,4
Viewing Angle	2θ <sub>1/2</sub>	Red Green		30 30		deg	Note 2 (Fig.5)
Peak Emission	λ <sub>p</sub>	Red Green		650 565		nm	Measurement @Peak (Fig.1)
Dominant Wavelength	λ <sub>d</sub>	Red Green	634 565	639 569	644 578	nm	Note 3
Spectral Line Half-Width	Δλ	Red Green		20 30		nm	
Forward Voltage	V <sub>F</sub>	Red Green		2.0 2.1	2.4 2.6	V	I <sub>F</sub> = 20mA
Reverse Current	I <sub>R</sub>	Red Green			100	μA	Note 5 V <sub>R</sub> = 5V,

Note: 1. Luminous intensity is measured with a light sensor and filter combination that approximates the CIE (Commission International De L'Eclairage) eye-response curve.

2. θ<sub>1/2</sub> is the off-axis angle at which the luminous intensity is half the axial luminous intensity.

3. The dominant wavelength, λ<sub>d</sub> is derived from the CIE chromaticity diagram and represents the single wavelength which defines the color of the device.

4. The I<sub>v</sub> guarantee should be added ±15%.

5. Reverse Voltage (V<sub>R</sub>) condition is applied for I<sub>R</sub> test only. The device is not designed for reverse operation.

## Property of Lite-On Only

### Typical Electrical / Optical Characteristics Curves

(25°C Ambient Temperature Unless Otherwise Noted)

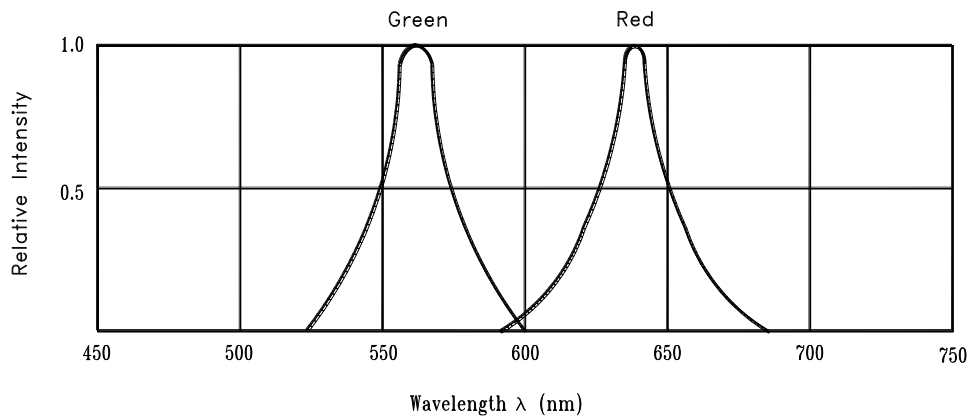

Fig.1 Relative Intensity vs. Wavelength

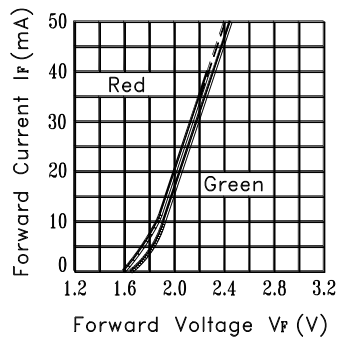

Fig.2 Forward Current vs. Forward Voltage

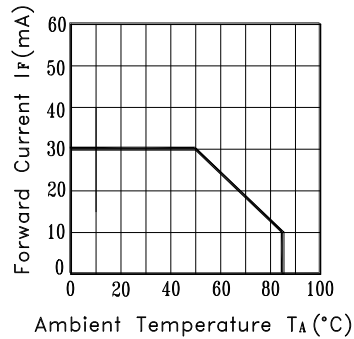

Fig.3 Forward Current Derating Curve

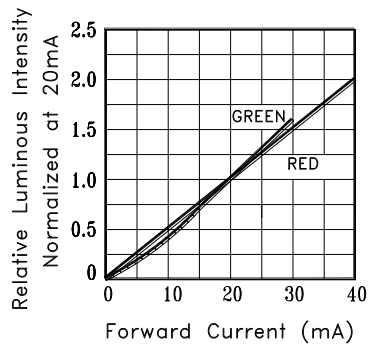

Fig.4 Relative Luminous Intensity vs. Forward Current

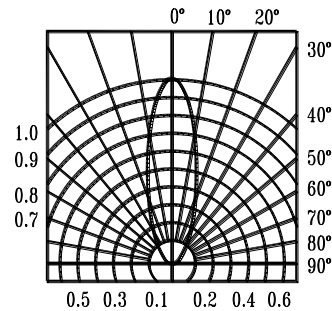

Fig.5 Spatial Distribution

**Bin Table Specifications**

<b>Luminous Intensity AllnGaP Red Unit : mcd @20mA</b>		
<b>Bin Code</b>	<b>Min.</b>	<b>Max.</b>
M	520	680
N	680	880
P	880	1150
Q	1150	1500

<b>Luminous Intensity AllnGaP Green Unit : mcd @20mA</b>		
<b>Bin Code</b>	<b>Min.</b>	<b>Max.</b>
M	520	680
N	680	880
P	880	1150
Q	1150	1500

Note: Tolerance of each bin limit is  $\pm 15\%$

Bin Code : X-X (Luminous Intensity RED– Luminous Intensity GREEN)

Property of Lite-On Only

## Packing Spec

**500 or 200 pcs per packing bag**

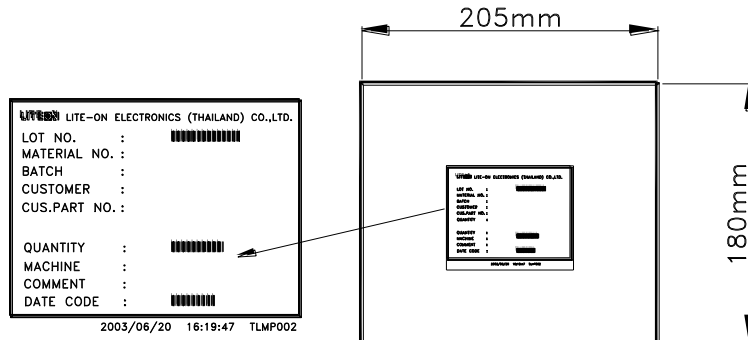

**10 packing bags per inner carton  
total 5,000 pcs per inner carton**

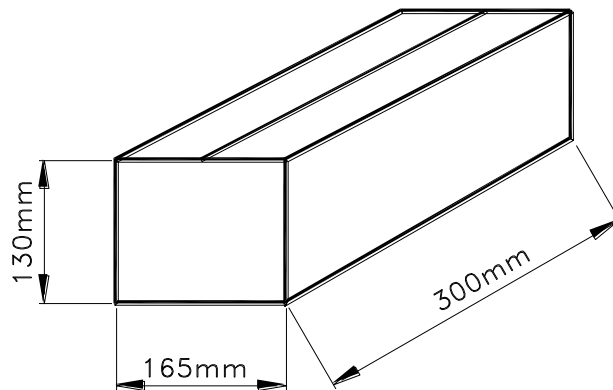

**8 Inner cartons per outer carton  
total 40,000 pcs per outer carton**

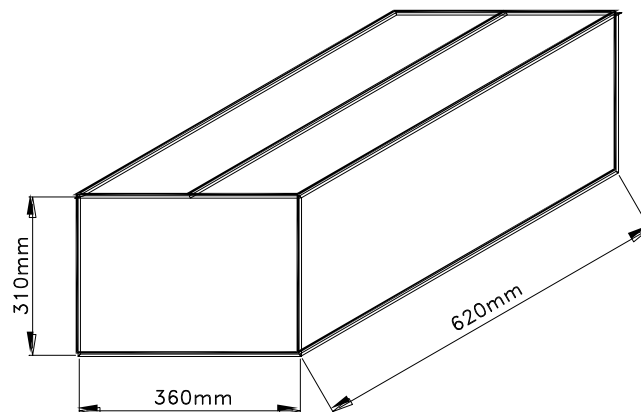

## CAUTIONS

### 1. Application

The LEDs described here are intended to be used for ordinary electronic equipment (such as office equipment, communication equipment and household applications). Consult Liteon's Sales in advance for information on applications in which exceptional reliability is required, particularly when the failure or malfunction of the LEDs may directly jeopardize life or health (such as in aviation, transportation, traffic control equipment, medical and life support systems and safety devices).

### 2. Storage

The storage ambient for the LEDs should not exceed 30°C temperature or 70% relative humidity. It is recommended that LEDs out of their original packaging are used within three months. For extended storage out of their original packaging, it is recommended that the LEDs be stored in a sealed container with appropriate desiccant or in desiccators with nitrogen ambient.

### 3. Cleaning

Use alcohol-based cleaning solvents such as isopropyl alcohol to clean the LEDs if necessary.

### 4. Lead Forming & Assembly

During lead forming, the leads should be bent at a point at least 3mm from the base of LED lens. Do not use the base of the lead frame as a fulcrum during forming. Lead forming must be done before soldering, at normal temperature. During assembly on PCB, use minimum clinch force possible to avoid excessive mechanical stress.

### 5. Soldering

When soldering, leave a minimum of 2mm clearance from the base of the lens to the soldering point. Dipping the lens into the solder must be avoided. Do not apply any external stress to the lead frame during soldering while the LED is at high temperature.

Recommended soldering conditions :

Soldering iron		Wave soldering	
Temperature	350 °C Max.	Pre-heat	100°C Max.
Soldering time	3.0 Sec Max. (one time only)	Pre-heat time	60 sec. Max.
		Solder wave	260°C Max.
		Soldering time	5 sec. Max.

Note: Excessive soldering temperature and/or time might result in deformation of the LED lens or catastrophic failure of the LED. IR reflow is not suitable process for through hole type LED lamp product.



## 6. Drive Method

An LED is a current-operated device. In order to ensure intensity uniformity on multiple LEDs connected in parallel in an application, it is recommended that a current limiting resistor be incorporated in the drive circuit, in series with each LED as shown in Circuit A below.

**Circuit model A**

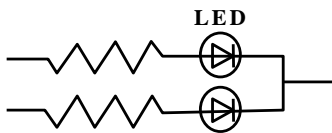

**Circuit model B**

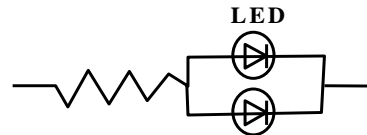

(A) Recommended circuit

(B) The brightness of each LED might appear different due to the differences in the I-V characteristics of those LEDs

## 7. ESD (Electrostatic Discharge)

Static Electricity or power surge will damage the LED.

Suggestions to prevent ESD damage:

- Use a conductive wrist band or anti- electrostatic glove when handling these LEDs
- All devices, equipment, and machinery must be properly grounded
- Work tables, storage racks, etc. should be properly grounded
- Use ion blower to neutralize the static charge which might have built up on surface of the LEDs plastic lens as a result of friction between LEDs during storage and handing

Suggested checking list :

Training and Certification

1. Everyone working in a static-safe area is ESD-certified?
2. Training records kept and re-certification dates monitored?

Static-Safe Workstation & Work Areas

1. Static-safe workstation or work-areas have ESD signs?
2. All surfaces and objects at all static-safe workstation and within 1 ft measure less than 100V?
3. All ionizer activated, positioned towards the units?
4. Each work surface mats grounding is good?

Personnel Grounding

1. Every person (including visitors) handling ESD sensitive (ESDS) items wear wrist strap, heel strap or conductive shoes with conductive flooring?
2. If conductive footwear used, conductive flooring also present where operator stand or walk?
3. Garments, hairs or anything closer than 1 ft to ESD items measure less than 100V\*?
4. Every wrist strap or heel strap/conductive shoes checked daily and result recorded for all DLs?
5. All wrist strap or heel strap checkers calibration up to date?

Note: \*50V for Blue LED.

Device Handling

1. Every ESDS items identified by EIA-471 labels on item or packaging?
2. All ESDS items completely inside properly closed static-shielding containers when not at static-safe workstation?
3. No static charge generators (e.g. plastics) inside shielding containers with ESDS items?
4. All flexible conductive and dissipative package materials inspected before reuse or recycle?

Others

1. Audit result reported to entity ESD control coordinator?
2. Corrective action from previous audits completed?
3. Are audit records complete and on file?

**8. Others**

The appearance and specifications of the product may be modified for improvement, without prior notice.