



Through Hole Lamp Product Data Sheet LTL760RGBEBJ

Spec No. :DS20-2018-0013
Effective Date: 09/11/2020
Revision: A

LITE-ON DCC

RELEASE

BNS-OD-FC001/A4

Through Hole Lamp
LTL760RGBEBJ

Through Hole Lamp

LTL760RGBEBJ

<u>Rev</u>	<u>Description</u>	<u>By</u>	<u>Date</u>
Above data for PD and Customer tracking only			
-	(RDR-20170211-02) Upload on OPNC.	Lance	01/08/2018
A	Update note information in Electrical / Optical test condition column on page 3	Norah	9/2/2020

Through Hole Lamp LTL760RGBEBJ

1. Description

Through hole LEDs are offered in a variety of packages such as 3mm, 4mm, 5mm, rectangular, and cylinder which are suitable for all applications requiring status indication. Several intensity and viewing angle choices are available in each color for design flexibility.

1.1. Features

- Lead(Pb) free products and RoHS compliant.
- Low power consumption & High efficiency.
- Versatile mounting on P.C. Board or panel.
- RGB lamp & White Diffused Lens.

1.2. Applications

- Communication
- Computer
- Consumer
- Home appliance
- Industrial

2. Outline Dimensions

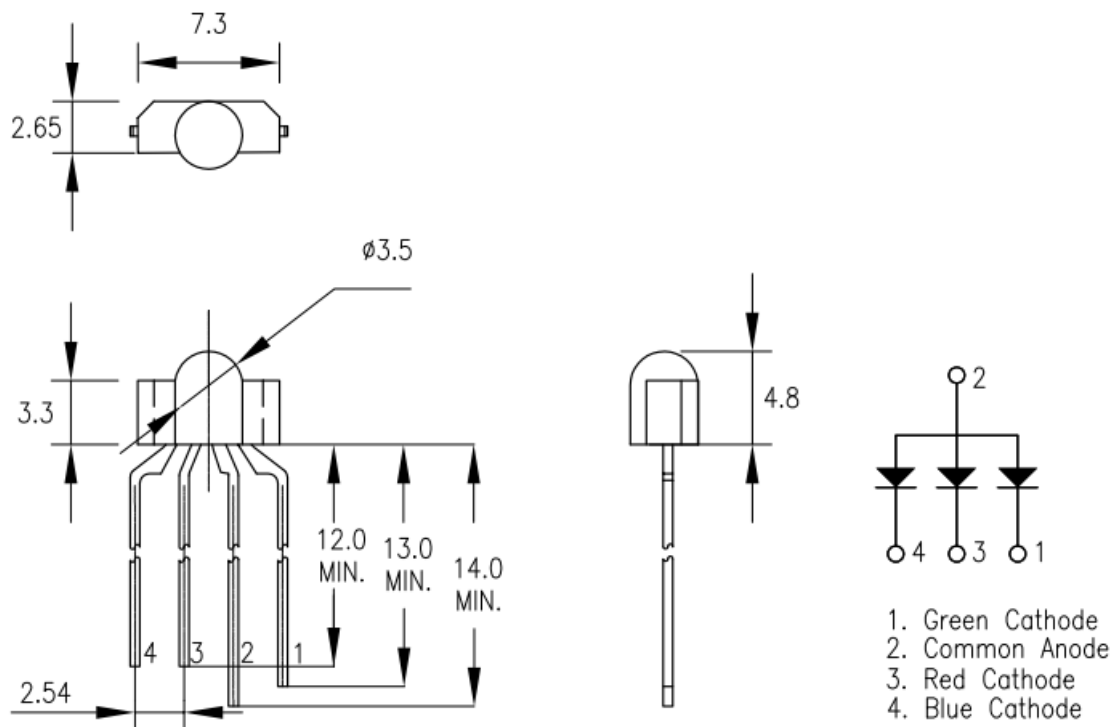

Notes :

1. All dimensions are in millimeters (inches).
2. Tolerance is ± 0.25 mm (.010") unless otherwise noted.
3. Protruded resin under flange is 1.0mm (.04") max.
4. Lead spacing is measured where the leads emerge from the package.
5. Specifications are subject to change without notice.

Through Hole Lamp LTL760RGBEBJ

3. Absolute Maximum Ratings at TA=25°C

Parameter	Red	Green	Blue	Unit
Power Dissipation	81	108	108	mW
Peak Forward Current (1/10 Duty Cycle, 0.1ms Pulse Width)	90	100	100	mA
DC Forward Current	30	30	30	mA
Derating Linear From 30°C	0.36	0.36	0.36	mA/°C
Operating Temperature Range	-40°C to + 85°C			
Storage Temperature Range	-40°C to + 100°C			
Lead Soldering Temperature [2.0mm(.0787") From Body]	260°C for 5 Seconds Max.			

4. Electrical / Optical Characteristics at TA=25°C

Parameter	Symbol	Color	Min.	Typ.	Max.	Unit	Test Condition
Luminous Intensity	I_v	-	100		310	mcd	Red IF = 4.5mA , Green IF = 2mA , Blue IF = 2mA , Note 1,4
Viewing Angle	$2\theta_{1/2}$	-		110		deg	Note 2 (Fig.6)
Chromaticity Coordinates	x	-		0.287		nm	Red IF = 4.5mA , Green IF = 2mA , Blue IF = 2mA , Note 5
	y			0.292			
Forward Voltage	V_F	Red	1.4		2.4	V	Red IF = 4.5mA , Green IF = 2mA , Blue IF = 2mA ,
		Green	2.2		3.2		
		Blue	2.2		3.2		
Reverse Current	I_R	Red			100	μA	$V_R = 5V$, Note 6
		Green			100		
		Blue			100		

NOTES:

- Luminous intensity is measured with a light sensor and filter combination that approximates the CIE eye-response curve.
- $\theta_{1/2}$ is the off-axis angle at which the luminous intensity is half the axial luminous intensity.
- I_v classification code is marked on each packing bag.
- The I_v guarantee must be included with $\pm 15\%$ testing tolerance.
- The chromaticity coordinates (x, y) is derived from the 1931 CIE chromaticity diagram..
- Reverse voltage (V_R) condition is applied for I_R test only. The device is not designed for reverse operation.

Through Hole Lamp LTL760RGBEBJ

5. Typical Electrical / Optical Characteristics Curves

(25°C Ambient Temperature Unless Otherwise Noted)

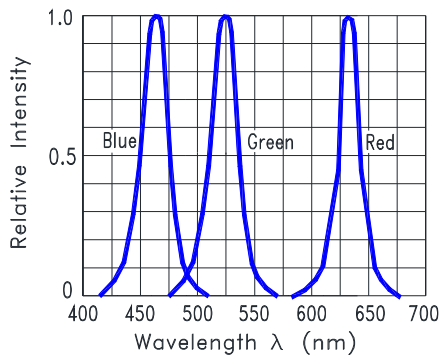

Fig.1 Relative Intensity VS. Wavelength

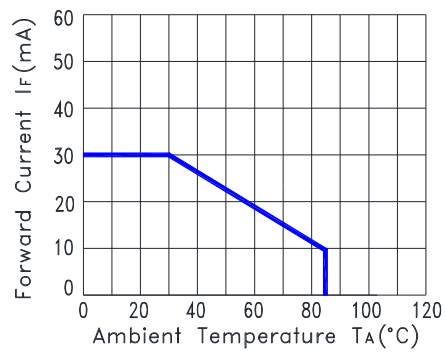

Fig.2 Forward Current Derating Curve

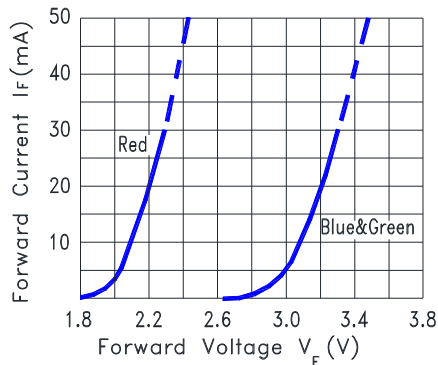

Fig.3 Forward Current vs. Forward Voltage

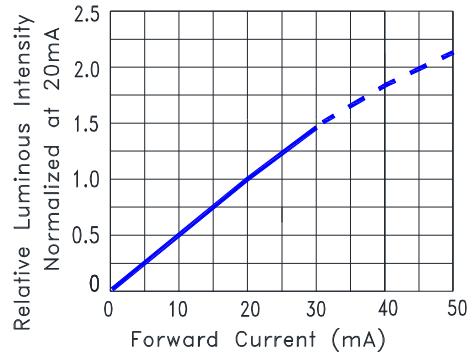

Fig.4 Relative Luminous Intensity vs. Forward Current

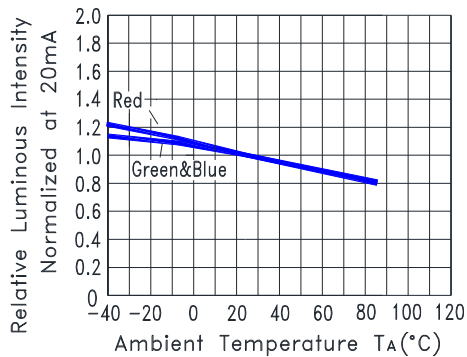

Fig.5 Relative Luminous Intensity vs. Ambient Temperature

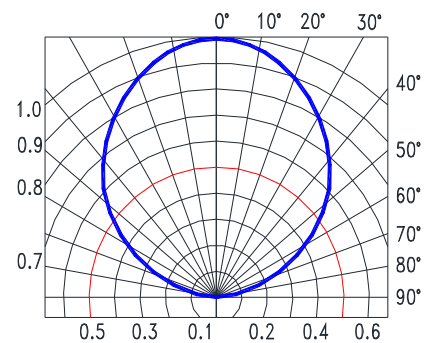
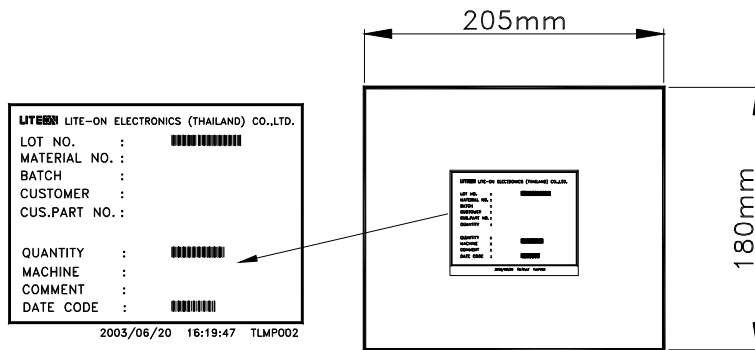

Fig.6 Spatial Distribution

**Through Hole Lamp
LTL760RGBEBJ**

6. Packing Spec.

500 or 200,100 pcs per packing bag



10 packing bags per Inner carton
Total 5,000 pcs per Inner carton

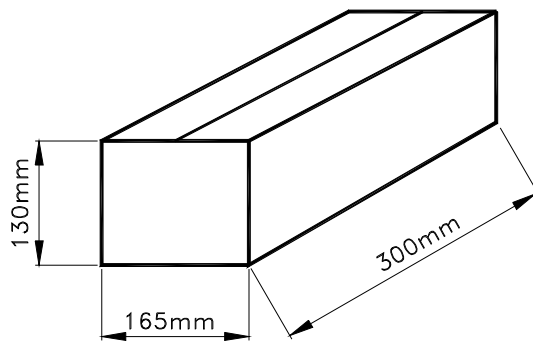

8 inner cartons per outer carton
Total 40,000 pcs per outer carton
In every shipping lot, only the last pack will be non-full packing

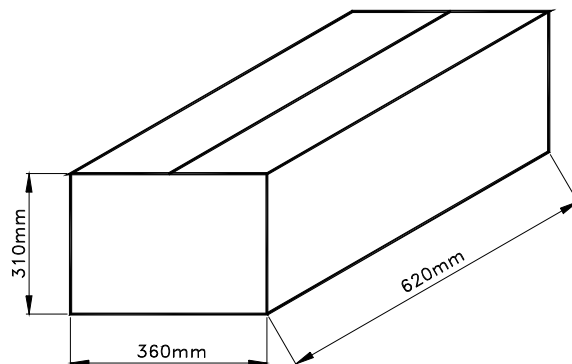

Through Hole Lamp LTL760RGBEJB

7. Bin Table Specification

Luminous Intensity Unit : mcd		
@ Red IF = 4.5mA, Green IF = 2mA, Blue IF = 2mA.		
Bin Code	Min.	Max.
F	100	140
G	140	180
H	180	240
J	240	310

Note: Tolerance of each bin limit is $\pm 15\%$

Hue Ranks	Chromaticity Coordinates, CC(x, y),				
	@ Red IF = 4.5mA, Green IF = 2mA, Blue IF = 2mA.				
A1	x	0.2570	0.2770	0.2770	0.2570
	y	0.2400	0.2480	0.2680	0.2600
A2	x	0.2570	0.2770	0.2770	0.2570
	y	0.2600	0.2680	0.2880	0.2800
A3	x	0.2570	0.2770	0.2770	0.2570
	y	0.2800	0.2880	0.3080	0.3000
A4	x	0.2570	0.2770	0.2770	0.2570
	y	0.3000	0.3080	0.3280	0.3200
B1	x	0.2770	0.2970	0.2970	0.2770
	y	0.2480	0.2560	0.2760	0.2680
B2	x	0.2770	0.2970	0.2970	0.2770
	y	0.2680	0.2760	0.2960	0.2880
B3	x	0.2770	0.2970	0.2970	0.2770
	y	0.2880	0.2960	0.3160	0.3080
B4	x	0.2770	0.2970	0.2970	0.2770
	y	0.3080	0.3160	0.3360	0.3280
C1	x	0.2970	0.3170	0.3170	0.2970
	y	0.2560	0.2640	0.2840	0.2760
C2	x	0.2970	0.3170	0.31700	0.2970
	y	0.2760	0.2840	0.3040	0.2960

Through Hole Lamp LTL760RGBEBJ

Hue Ranks	Chromaticity Coordinates, CC(x, y), @ Red IF = 4.5mA, Green IF = 2mA, Blue IF = 2mA.				
		x	0.2970	0.3170	0.3170
C3	y	0.2960	0.3040	0.3240	0.3160
		x	0.2970	0.3170	0.3170
C4	y	0.3160	0.3240	0.3440	0.3360
		x	0.3170	0.3370	0.3370
D1	y	0.2640	0.2720	0.2920	0.2840
		x	0.3170	0.3370	0.3370
D2	y	0.2840	0.2920	0.3120	0.3040
		x	0.3170	0.3370	0.3370
D3	y	0.3040	0.3120	0.3320	0.3240
		x	0.3170	0.3370	0.3370
D4	y	0.3240	0.3320	0.3520	0.3440

Note: Color Coordinates Measurement allowance is ± 0.01

C.I.E. 1931 Chromaticity Diagram

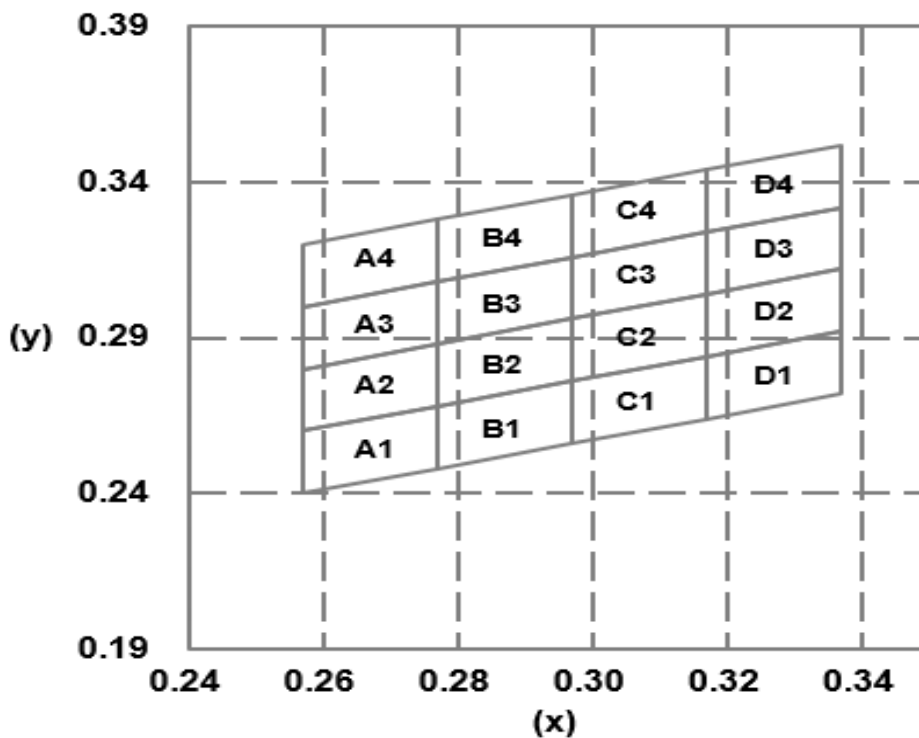

Through Hole Lamp LTL760RGBEBJ

8. CAUTIONS

8.1. Application

This LED lamp is good for application of indoor and outdoor sign, also ordinary electronic equipment.

8.2. Storage

The storage ambient for the LEDs should not exceed 30°C temperature or 70% relative humidity. It is recommended that LEDs out of their original packaging are used within three months. For extended storage out of their original packaging, it is recommended that the LEDs be stored in a sealed container with appropriate desiccant or in desiccators with nitrogen ambient.

8.3. Cleaning

Use alcohol-based cleaning solvents such as isopropyl alcohol to clean the LEDs if necessary.

8.4. Lead Forming & Assembly

During lead forming, the leads should be bent at a point at least 3mm from the base of LED lens. Do not use the base of the lead frame as a fulcrum during forming. Lead forming must be done before soldering, at normal temperature. During assembly on PCB, use minimum clinch force possible to avoid excessive mechanical stress.

8.5. Soldering

When soldering, leave a minimum of 2mm clearance from the base of the lens to the soldering point. Dipping the lens into the solder must be avoided. Do not apply any external stress to the lead frame during soldering while the LED is at high temperature.

Recommended soldering conditions:

Soldering iron		Wave soldering	
Temperature	350°C Max.	Pre-heat	100°C Max.
Soldering time	3 seconds Max. (one time only)	Pre-heat time	60 seconds Max.
Position	No closer than 2mm from the base of the epoxy bulb	Solder wave	260°C Max.
		Soldering time	5 seconds Max.
		Dipping Position	No lower than 2mm from the base of the epoxy bulb

Note: Excessive soldering temperature and/or time might result in deformation of the LED lens or catastrophic failure of the LED. IR reflow is not suitable process for through hole type LED lamp product.

8.6. Drive Method

An LED is a current-operated device. In order to ensure intensity uniformity on multiple LEDs connected in parallel in an application, it is recommended that a current limiting resistor be incorporated in the drive circuit, in series with each LED as shown in Circuit A below.

Circuit model (A)

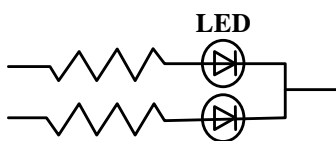

Circuit model (B)

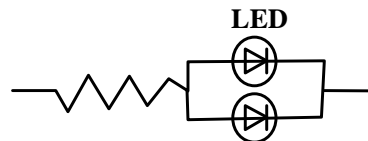

(A) Recommended circuit

(B) The brightness of each LED might appear different due to the differences in the I-V characteristics of those LEDs.

Through Hole Lamp LTL760RGBEBJ

8.7. ESD (Electrostatic Discharge)

Static Electricity or power surge will damage the LED.

Suggestions to prevent ESD damage:

- Use a conductive wrist band or anti- electrostatic glove when handling these LEDs
- All devices, equipment, and machinery must be properly grounded
- Work tables, storage racks, etc. should be properly grounded
- Use ion blower to neutralize the static charge which might have built up on surface of the LEDs plastic lens as a result of friction between LEDs during storage and handing

Suggested checking list:

Training and Certification

- 8.7.1.1. Everyone working in a static-safe area is ESD-certified?
- 8.7.1.2. Training records kept and re-certification dates monitored?

Static-Safe Workstation & Work Areas

- 8.7.2.1. Static-safe workstation or work-areas have ESD signs?
- 8.7.2.2. All surfaces and objects at all static-safe workstation and within 1 ft measure less than 100V?
- 8.7.2.3. All ionizer activated, positioned towards the units?
- 8.7.2.4. Each work surface mats grounding is good?

Personnel Grounding

- 8.7.3.1. Every person (including visitors) handling ESD sensitive (ESDS) items wear wrist strap, heel strap or conductive shoes with conductive flooring?
- 8.7.3.2. If conductive footwear used, conductive flooring also present where operator stand or walk?
- 8.7.3.3. Garments, hairs or anything closer than 1 ft to ESD items measure less than 100V*?
- 8.7.3.4. Every wrist strap or heel strap/conductive shoes checked daily and result recorded for all DLs?
- 8.7.3.5. All wrist strap or heel strap checkers calibration up to date?
Note: *50V for Blue LED.

Device Handling

- 8.7.4.1. Every ESDS items identified by EIA-471 labels on item or packaging?
- 8.7.4.2. All ESDS items completely inside properly closed static-shielding containers when not at static-safe workstation?
- 8.7.4.3. No static charge generators (e.g. plastics) inside shielding containers with ESDS items?
- 8.7.4.4. All flexible conductive and dissipative package materials inspected before reuse or recycle?

Others

- 8.7.5.1. Audit result reported to entity ESD control coordinator?
- 8.7.5.2. Corrective action from previous audits completed?
- 8.7.5.3. Are audit records complete and on file?

Through Hole Lamp LTL760RGBEJB

9. Reliability Test

Classification	Test Item	Test Condition	Sample Size	Reference Standard
Endurance Test	Operation Life	Ta = Under room temperature IF = per datasheet maximum drive current Test Time= 1000hrs	22 PCS (CL=90%; LTPD=10%)	MIL-STD-750D:1026 (1995) MIL-STD-883G:1005 (2006)
	High Temperature High Humidity storage	Ta = 60°C RH = 90% Test Time= 240hrs	22 PCS (CL=90%; LTPD=10%)	MIL-STD-202G:103B (2002) JEITA ED-4701:100 103 (2001)
	High Temperature Storage	Ta= 105 ± 5°C Test Time= 1000hrs	22 PCS (CL=90%; LTPD=10%)	MIL-STD-750D:1031 (1995) MIL-STD-883G:1008 (2006) JEITA ED-4701:200 201 (2001)
	Low Temperature Storage	Ta= -55 ± 5°C Test Time= 1000hrs	22 PCS (CL=90%; LTPD=10%)	JEITA ED-4701:200 202 (2001)
Environmental Test	Temperature Cycling	100°C ~ 25°C ~ -40°C ~ 25°C 30mins 5mins 30mins 5mins 30 Cycles	22 PCS (CL=90%; LTPD=10%)	MIL-STD-750D:1051 (1995) MIL-STD-883G:1010 (2006) JEITA ED-4701:100 105 (2001) JESD22-A104C (2005)
	Thermal Shock	100 ± 5°C ~ -30°C ± 5°C 15mins 15mins 30 Cycles (<20 secs transfer)	22 PCS (CL=90%; LTPD=10%)	MIL-STD-750D:1056 (1995) MIL-STD-883G:1011 (2006) MIL-STD-202G:107G (2002) JESD22-A106B (2004)
	Solder Resistance	T. sol = 260 ± 5°C Dwell Time= 10±1 seconds 3mm from the base of the epoxy bulb	11 PCS (CL=90%; LTPD=18.9%)	MIL-STD-750D:2031(1995) JEITA ED-4701: 300 302 (2001)
	Solderability	T. sol = 245 ± 5°C Dwell Time= 5 ± 0.5 seconds (Lead Free Solder, Coverage ≥ 95% of the dipped surface)	11 PCS (CL=90%; LTPD=18.9%)	MIL-STD-750D:2026 (1995) MIL-STD-883G:2003 (2006) MIL-STD-202G:208H (2002) IPC/EIA J-STD-002 (2004)
	Soldering Iron	T. sol = 350 ± 5°C Dwell Time= 3.5 ± 0.5 seconds	11 PCS (CL=90%; LTPD=18.9%)	MIL-STD-202G:208H (2002) JEITA ED-4701:300 302 (2001)

10. Others

The appearance and specifications of the product may be modified for improvement, without prior notice.