



LED Display
Product Data Sheet
LTD-4830CKR-P

Spec No. :DS30-2013-0042
Effective Date: 02/18/2020
Revision: B

LITE-ON DCC

RELEASE

BNS-OD-FC001/A4

**LED DISPLAY
LTD-4830CKR-P**

LED DISPLAY

LTD-4830CKR-P

<u>Rev</u>	<u>Description</u>	<u>By</u>	<u>Date</u>
01	Preliminary Spec.	Reo Lin	08/15/2012
Above data for PD and Customer tracking only			
-	NPPR Received and Upload on System	Reo Lin	06/12/2013
A	Update Packing spec. in page 10	Reo Lin	01/30/2020
B	Add Bin Table in page 7	Reo Lin	02/07/2020

LED DISPLAY LTD-4830CKR-P

1. Description

The LTS-4830CKR-P is a 0.39 inch (10.0 mm) digit height dual digit SMD display. This device uses AS-AllnGap Super Red LED chips (AllnGap epi on GaAs substrate). The display has gray face and white segments.

1.1 Features

- 0.39 inch (10.0 mm) DIGIT HEIGHT
- CONTINUOUS UNIFORM SEGMENTS
- LOW POWER REQUIREMENT
- EXCELLENT CHARACTERS APPEARANCE
- HIGH BRIGHTNESS & HIGH CONTRAST
- WIDE VIEWING ANGLE
- SOLID STATE RELIABILITY
- CATEGORIZED FOR LUMINOUS INTENSITY.
- LEAD-FREE PACKAGE (ACCORDING TO ROHS)

1.2 Device

Part No	Description
AllnGaP Super Red	Common Anode
LTD-4830CKR-P	Rt. Hand Decimal

LED DISPLAY LTD-4830CKR-P

2. Package Dimensions

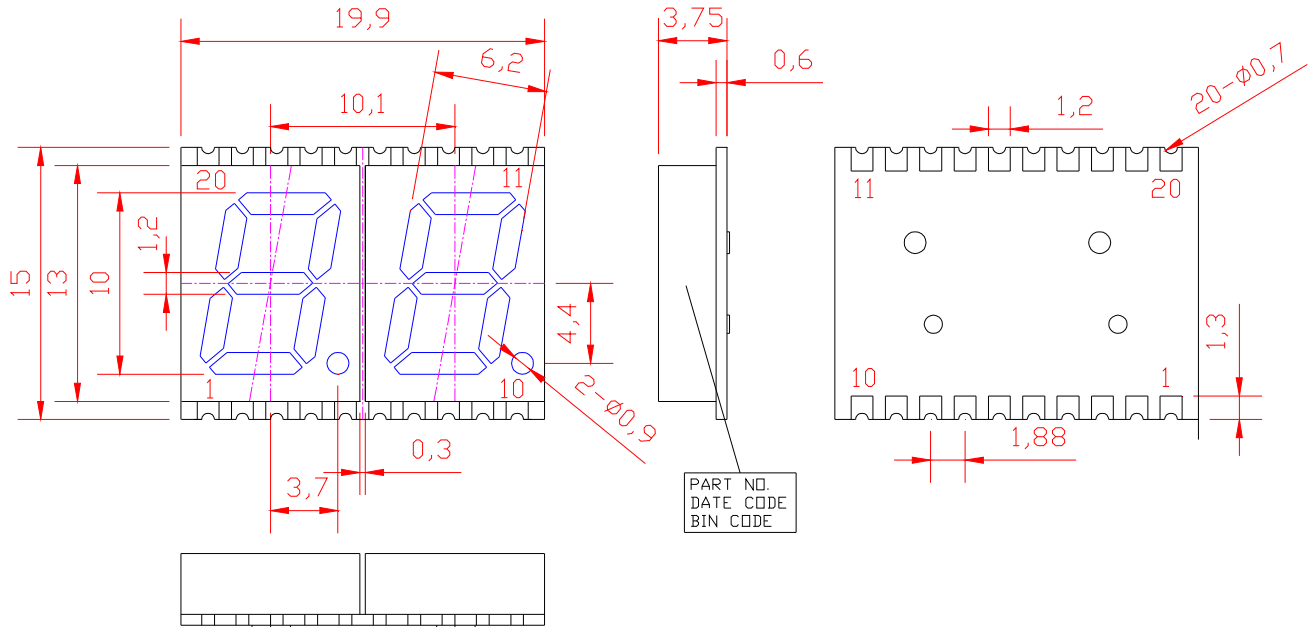

Notes :

1. All dimensions are in millimeters. Tolerances are ± 0.25 mm (0.01") unless otherwise noted
2. Foreign material on segment ≤ 10 mil
3. Ink contamination (surface) ≤ 20 mils
4. Bubble in segment ≤ 10 mil
5. Bending $\leq 1\%$ of reflector length
6. Plastic pin's burr max is 0.1 mm

**LED DISPLAY
LTD-4830CKR-P**

3. Internal Circuit Diagram

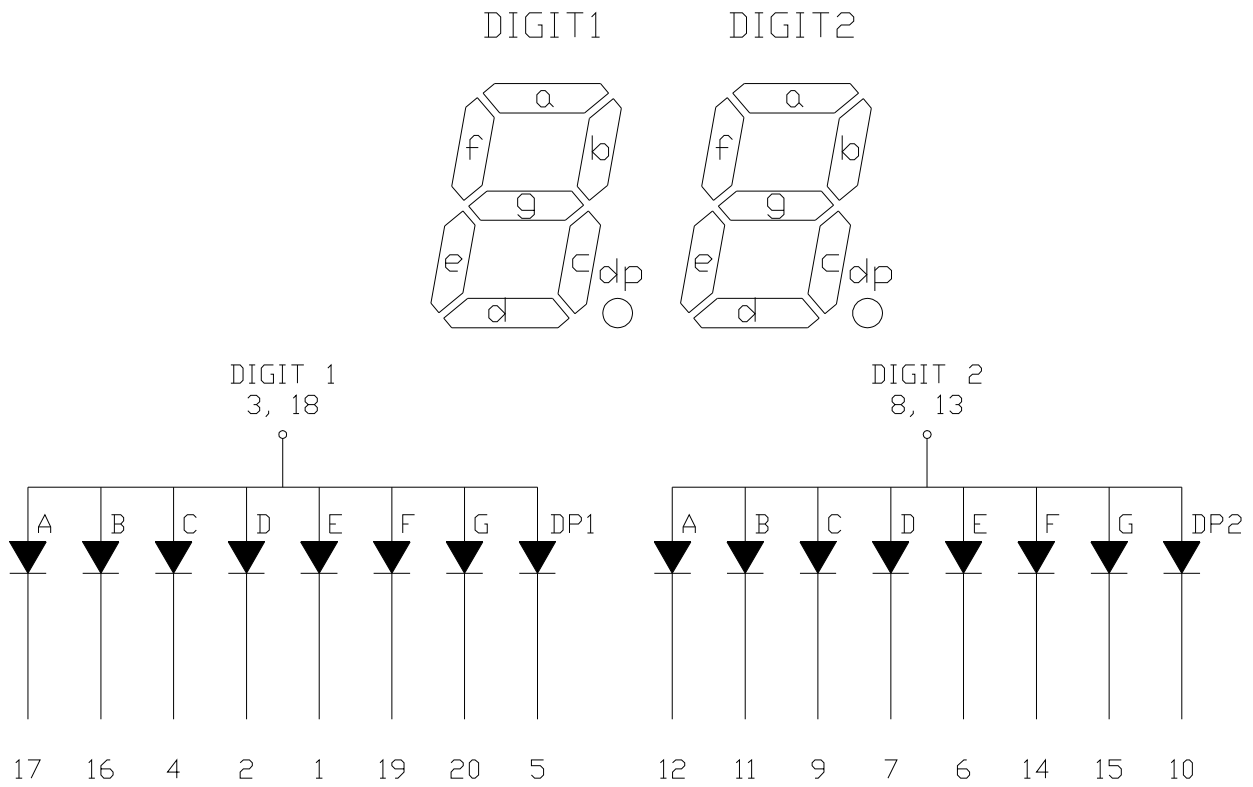

**LED DISPLAY
LTD-4830CKR-P**

4. Pin Connection

No	Connection
1	CATHODE E1
2	CATHODE D1
3	COMMON ANODE DIGIT 1
4	CATHODE C1
5	CATHODE DP1
6	CATHODE E2
7	CATHODE D2
8	COMMON ANODE DIGIT 2
9	CATHODE C2
10	CATHODE DP2
11	CATHODE B2
12	CATHODE A2
13	COMMON ANODE DIGIT 2
14	CATHODE F2
15	CATHODE G2
16	CATHODE B1
17	CATHODE A1
18	COMMON ANODE DIGIT 1
19	CATHODE F1
20	CATHODE G1

LED DISPLAY LTD-4830CKR-P

5. Rating and Characteristics

5.1. Absolute Maximum Rating at Ta=25°C

Parameter	Maximum Rating	Unit
Power Dissipation Per Segment	70	mW
Peak Forward Current Per Segment (1/10 Duty Cycle, 0.1ms Pulse Width)	90	mA
Continuous Forward Current Per Segment Derating Linear From 25°C Per Segment	25 0.28	mA mA/°C
Operating Temperature Range	-35°C to +105°C	
Storage Temperature Range	-35°C to +105°C	
Iron Soldering Conditions: 3 Seconds at 300°C (One time only)		

5.2. Electrical / Optical Characteristics at Ta=25°C

Parameter	Symbol	MIN.	TYP.	MAX.	Unit	Test Condition
Average Luminous Intensity Per Segment	IV	501	1700		μcd	IF=1mA
			22100		μcd	IF=10mA
Peak Emission Wavelength	λp		639		nm	IF=20mA
Spectral Line Half-Width	Δλ		20		nm	IF=20mA
Dominant Wavelength	λd		631		nm	IF=20mA
Forward Voltage Per Chip	VF		2.05	2.6	V	IF=20mA
Reverse Current Per Segment ⁽²⁾	IR			100	μA	VR=5V
Luminous Intensity Matching Ratio (Similar Light Area)	IV-m			2:1		IF=1mA

Notes :

- Luminous intensity is measured with a light sensor and filter combination that approximates the CIE (Commission International De L'Eclairage) eye-response curve
- Reverse voltage is only for IR test. It cannot continue to operate at this situation
- Cross talk specification $\leq 2.5\%$

LED DISPLAY LTD-4830CKR-P

5.3. Bin Range Distribution (Driver Current is 1 mA)

Bin	G	H	J	K	L
Min.	501	801	1301	2101	3401
Max.	800	1300	2100	3400	5400

Unit is μcd , Tolerance is +/-15%

LED DISPLAY LTD-4830CKR-P

5.4. Typical Electrical / Optical Characteristics Curves

(25°C Ambient Temperature Unless Otherwise Noted)

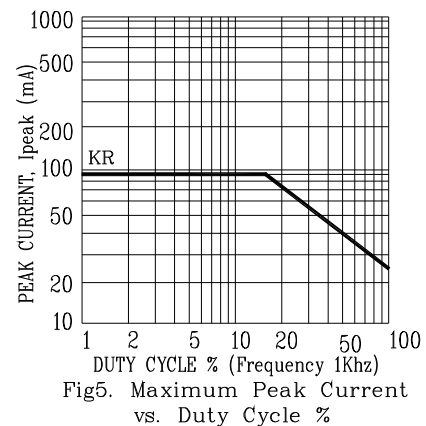
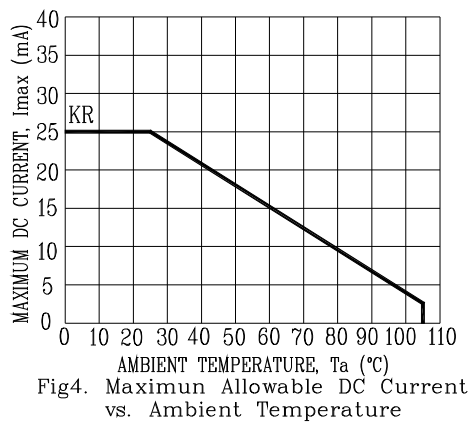
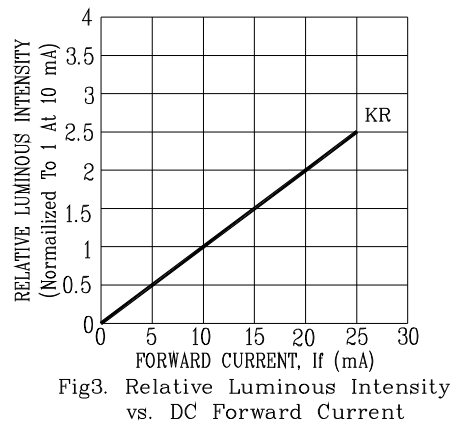
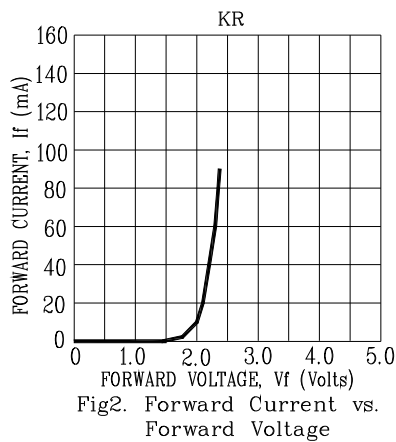
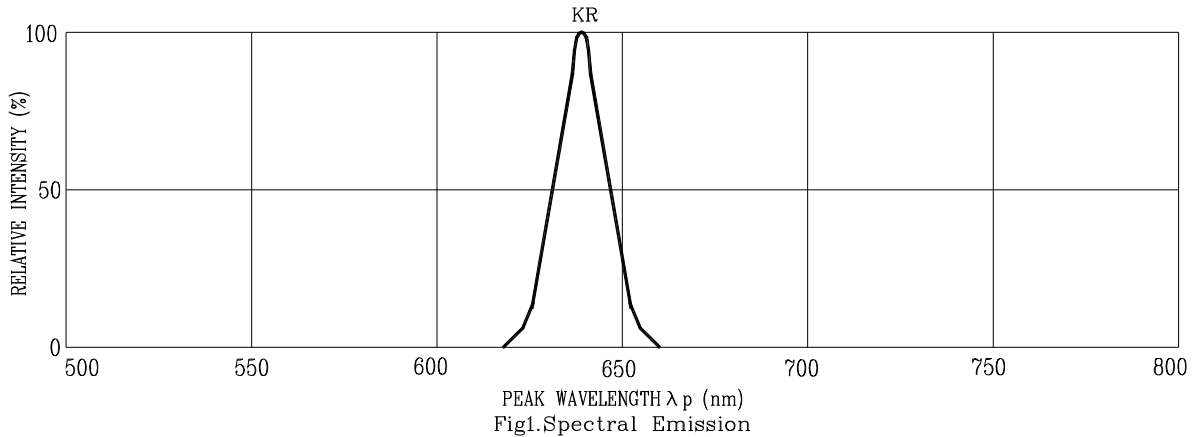

NOTE : KR=AlInGaP SUPER RED

LED DISPLAY LTD-4830CKR-P

6. SMT SOLDERING INSTRUCTION

(Number of reflow process shall be less than 2 times, and cooling process to normal temperature is required between the first and the second soldering process)

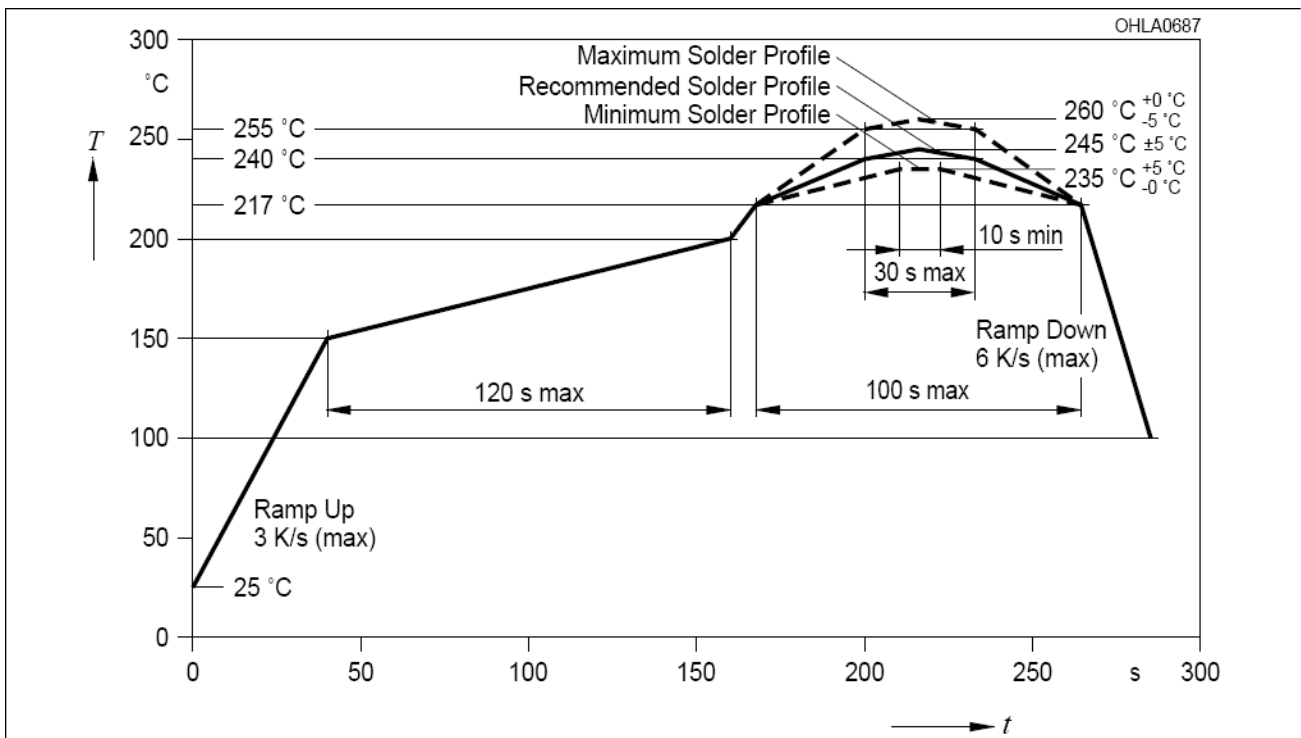

Notes :

1. Recommended soldering condition

Reflow Soldering (Two times only)		Soldering Iron (One time only)	
Pre-heat:	120~150°C.	Temperature	300°C Max.
Pre-heat time:	120sec. Max.	Soldering time	3sec. Max.
Peak temperature:	260°C Max.		
Soldering time:	5sec. Max.		

2. Number of reflow process shall be less than 2 times, and cooling process to normal temperature is required between the first and the second soldering process.

**LED DISPLAY
LTD-4830CKR-P**

7. Recommended Soldering Pattern

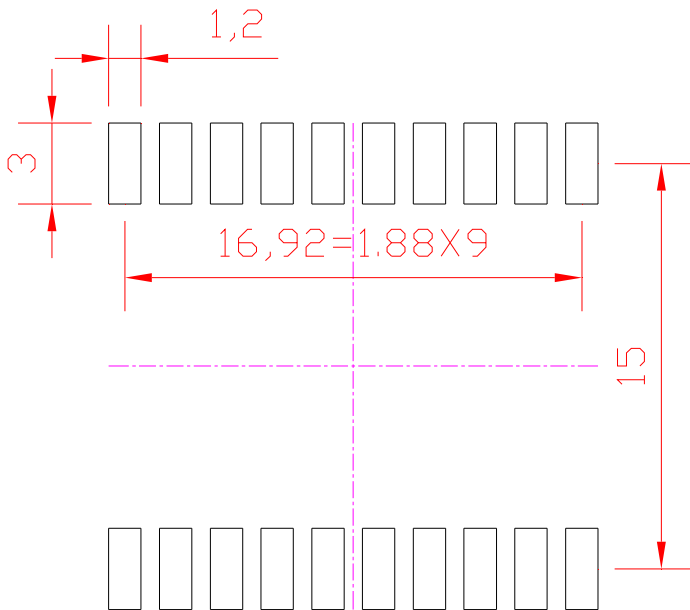

8. Packing Specification

8.1. Packing Reel Dimensions

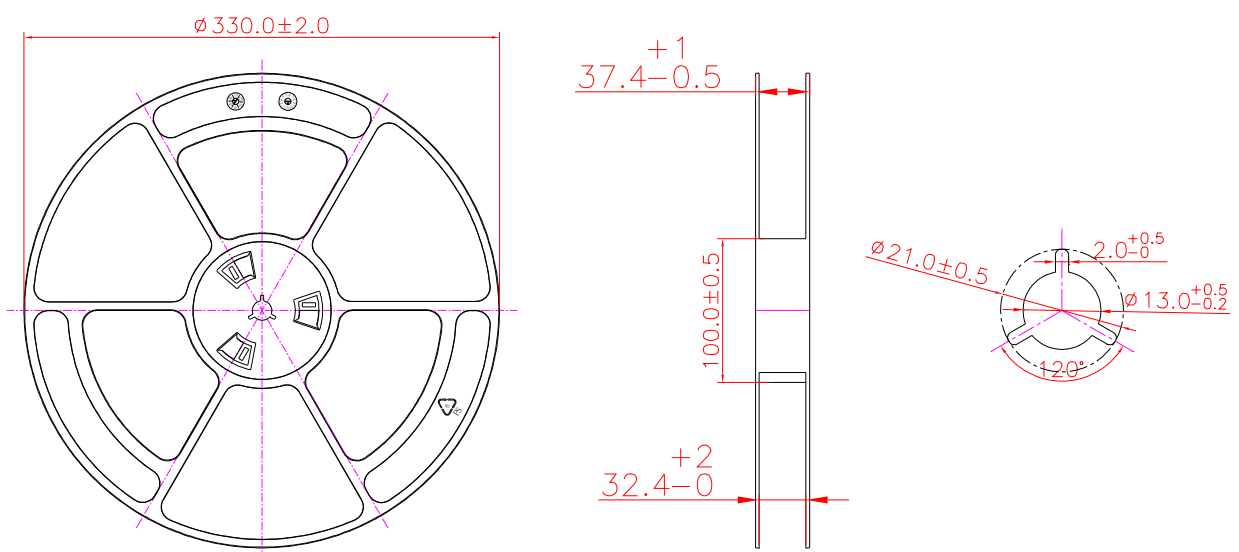

**LED DISPLAY
LTD-4830CKR-P**

8.2. Packing Carrier Dimensions

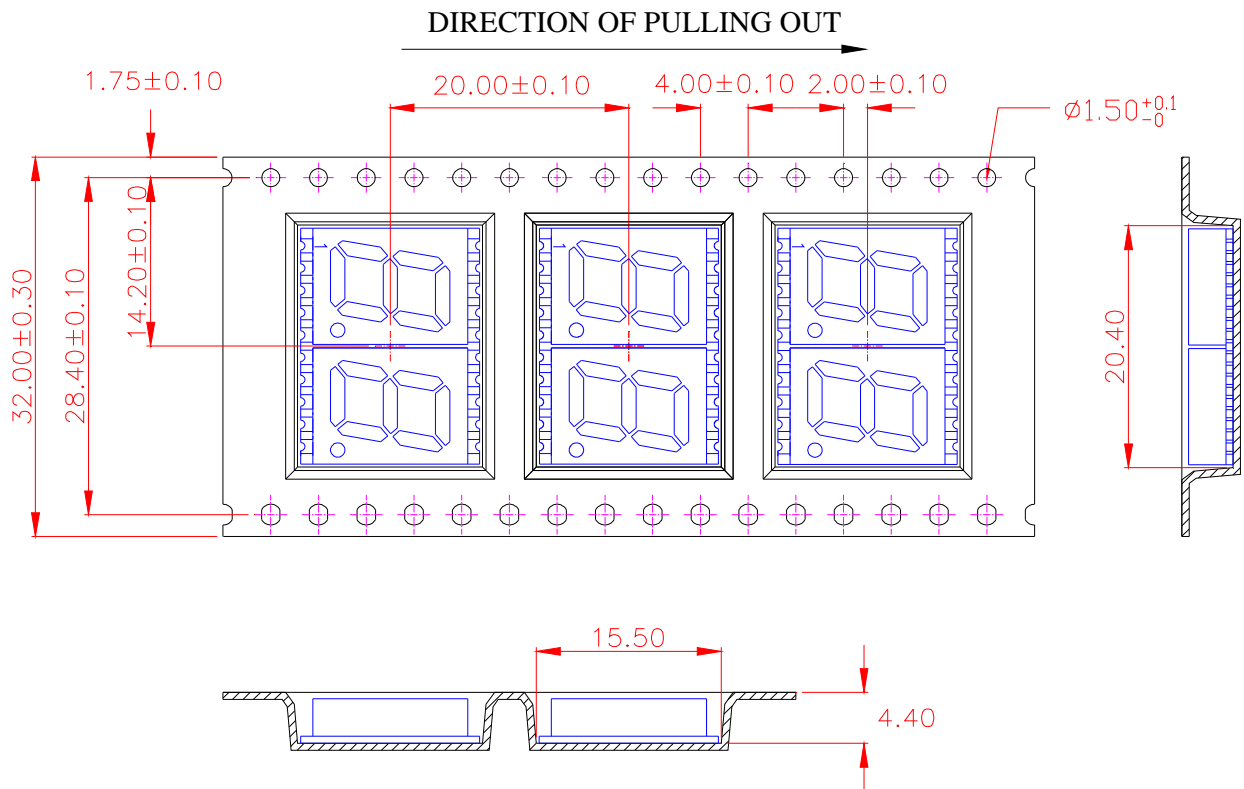

1. Component load per 13" reel : 550 pcs.
2. Minimum packing quantity is 200 pcs for remainders

8.3. Trailer part / Leader part

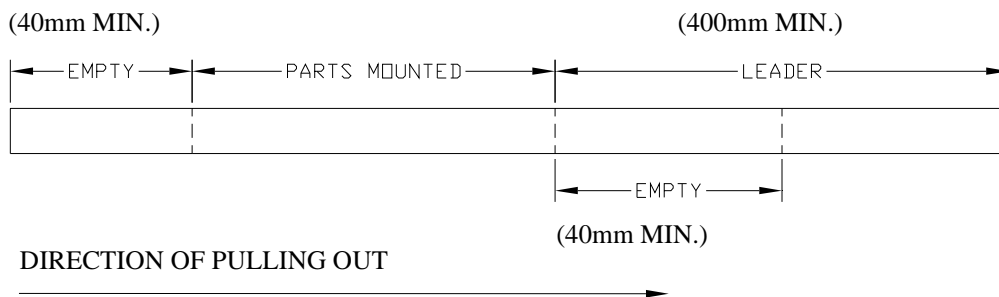

**LED DISPLAY
LTD-4830CKR-P**

9. Moisture Proof Packing

All N/D SMD displays are shipped in moisture proof package. The displays should be stored at 30°C or less and 60% RH or less. Once the package opened, moisture absorption begins. MSL level is 3

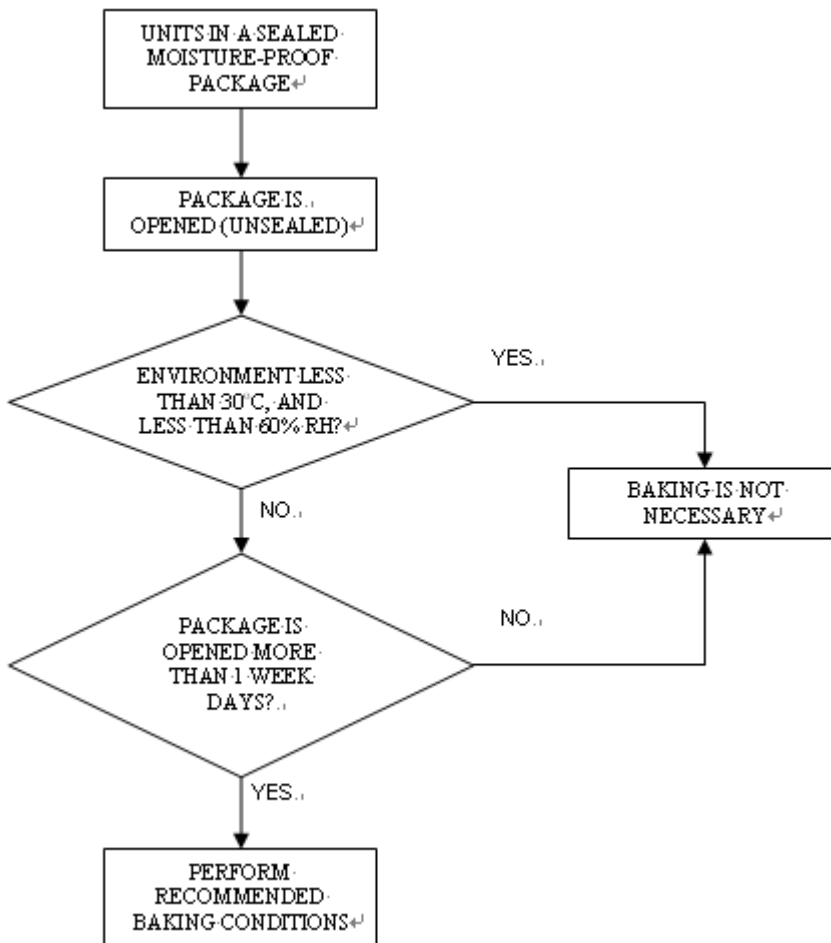

If the parts are not stored in dry conditions, they must be baked before reflow to prevent damage to the parts. Baking should only be done once

Package	Temperature	Time
In Reel	60°C	≥ 48hours
In Bulk	100°C	≥ 4hours
	125°C	≥ 2hours