



**SMD LED**  
**Product Data Sheet**  
**LTSA-T67RUWETA**

Spec No. :DS35-2020-0015  
Effective Date: 02/22/2020  
Revision: -

**LITE-ON DCC**

**RELEASE**

**BNS-OD-FC001/A4**

## SMD LED LTSA-T67RUWETA

### 1. Description

SMD LEDs from Lite-On are available in miniature sizes and special configurations for automated PC board assembly and space-sensitive applications. These SMD LEDs are suitable for use a wide variety of electronic equipment, e.g.: cordless and cellular phones, notebook computers and network systems etc...

#### 1.1 Features

- Meet ROHS
- White PLCC2 LED
- Package in 8mm tape on 7" diameter reels
- Preconditioning: accelerate to JEDEC level 2a
- Qualification refer to AEC-Q101 Ver. D
- EIA STD package
- I.C. compatible
- Compatible with automatic placement equipment
- Compatible with infrared reflow solder process

#### 1.2 Applications

- Automotive: accessory applications

### 2. Package Dimensions

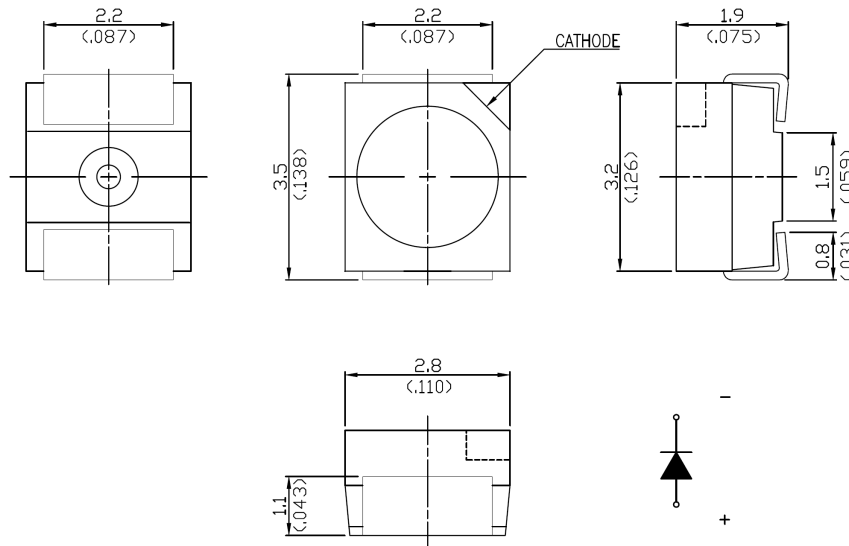

Part No.	Lens Color	Source Color
LTSA-T67RUWETA	Yellow	InGaN / White

#### Notes:

1. All dimensions are in millimeters.
2. Tolerance is  $\pm 0.2$  mm (.008") unless otherwise noted.

# SMD LED LTSA-T67RUWETA

## 3. Rating and Characteristics

### 3.1 Absolute Maximum Ratings at Ta=25°C

Parameter	LTSA-T67RUWETA	Unit
Power Dissipation	160	mW
Peak Forward Current (1/10 Duty Cycle, 0.1ms Pulse Width)	100	mA
DC Forward Current	50	mA
Operating Temperature Range	-40°C to +100°C	
Storage Temperature Range	-40°C to + 100°C	

### 3.2 Suggest IR Reflow Condition for Pb Free Process:

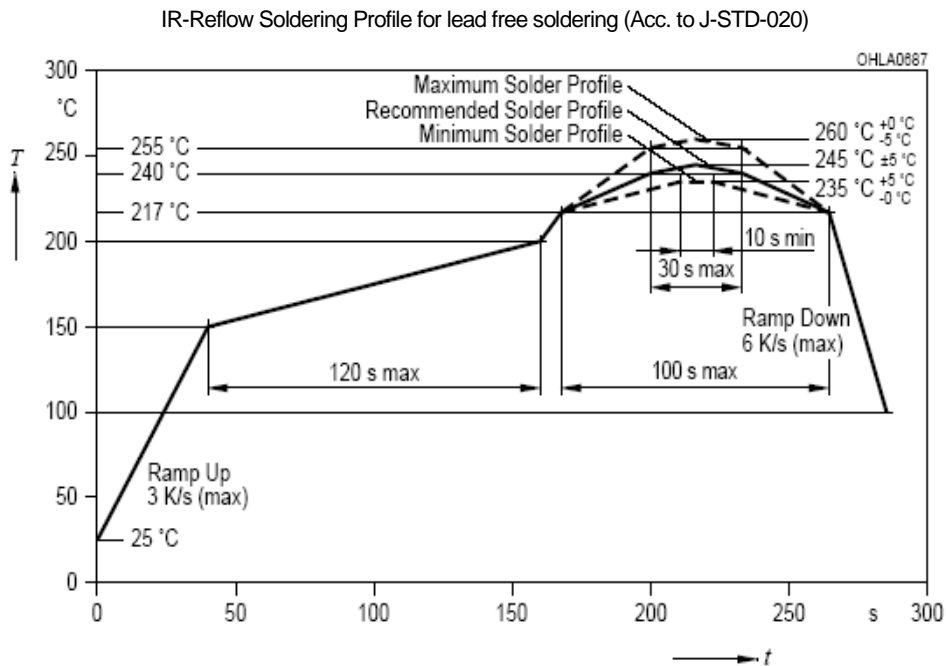

## SMD LED LTSA-T67RUWETA

### 3.3 Electrical / Optical Characteristics at Ta=25°C

Parameter	Symbol	Part No. LTSA-	Min.	Typ.	Max.	Unit.	Test Condition
Luminous Intensity	IV	T67RUWETA	1800	-	3550	mcd	IF = 20mA Note 1
Viewing Angle	2θ <sub>1/2</sub>	T67RUWETA		120		deg	Note 2 (Fig.5)
Chromaticity Coordinates	x	T67RUWETA		0.322		-	IF = 20mA Note 3
	y	T67RUWETA		0.313			
Forward Voltage	VF	T67RUWETA	2.4	-	3.2	V	IF = 20mA
Reverse Current	IR	T67RUWETA	-	-	10	μA	VR =5V Note 4

#### Notes:

1. Luminous intensity is measured with a light sensor and filter combination that approximates the CIE eye-response curve
2. θ<sub>1/2</sub> is the off-axis angle at which the luminous intensity is half the axial luminous intensity.
3. The chromaticity coordinates (x , y) is derived from the 1931 CIE chromaticity diagram
4. Reverse Voltage (VR) condition is applied to IR test only. The device is not designed for reverse operation.

**SMD LED  
LTSA-T67RUWETA**

**4. Bin Rank**

Batch Description on Label: Vf / Iv / Color ( Ex. D6/X1/KL )

**4.1 VF Rank**

Forward Voltage		Unit : V @ 20mA	
Bin Code	Min.	Max.	
D5	2.4	2.6	
D6	2.6	2.8	
D7	2.8	3.0	
D8	3.0	3.2	

Tolerance on each Voltage bin is +/-0.1V

**4.2 IV Rank**

Luminous Intensity		Unit : mcd @ 20mA	
Bin Code	Min.	Max.	
X1	1800	2240	
X2	2240	2800	
Y1	2800	3550	

Tolerance on each Intensity bin is +/-11%

# SMD LED LTSA-T67RUWETA

## 4.3 Color Rank

Color Bin Table						Test @20mA					
Bin Code	Color Bin Limits					Bin Code	Color Bin Limits				
	CIE-	Point1	Point2	Point3	Point4		CIE-	Point1	Point2	Point3	Point4
JL	x	0.2850	0.2910	0.3005	0.2960	MK	x	0.3197	0.3205	0.3288	0.3288
	y	0.2790	0.2680	0.2825	0.2955		y	0.3131	0.2956	0.3081	0.3282
JK	x	0.2910	0.2960	0.3045	0.3005	NL	x	0.3288	0.3288	0.3386	0.3386
	y	0.2680	0.2590	0.2715	0.2825		y	0.3282	0.3452	0.3591	0.3426
KL	x	0.2960	0.3005	0.3100	0.3070	NK	x	0.3288	0.3288	0.3386	0.3386
	y	0.2955	0.2825	0.2970	0.3120		y	0.3081	0.3282	0.3426	0.3235
KK	x	0.3005	0.3045	0.3130	0.3100	OL	x	0.3386	0.3484	0.3484	0.3386
	y	0.2825	0.2715	0.2840	0.2970		y	0.3426	0.3571	0.3730	0.3591
LL	x	0.3070	0.3100	0.3197	0.3189	OK	x	0.3386	0.3484	0.3484	0.3386
	y	0.3120	0.2970	0.3131	0.3302		y	0.3235	0.3388	0.3571	0.3426
LK	x	0.3100	0.3130	0.3205	0.3197	PL	x	0.3484	0.3582	0.3582	0.3484
	y	0.2970	0.2840	0.2956	0.3131		y	0.3571	0.3715	0.3792	0.3730
ML	x	0.3189	0.3197	0.3288	0.3288	PK	x	0.3484	0.3582	0.3582	0.3484
	y	0.3302	0.3131	0.3282	0.3452		y	0.3388	0.3542	0.3715	0.3571

Tolerance on each Hue bin (x, y) bin is +/- 0.01.

**SMD LED  
LTSA-T67RUWETA**

4.4 Chromaticity Coordinate

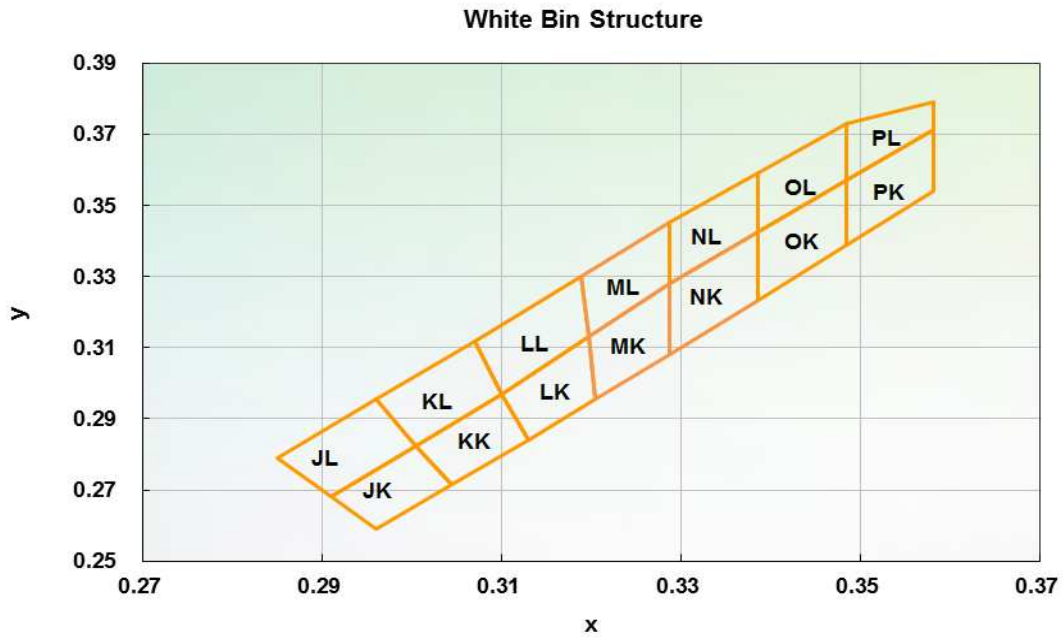

**SMD LED  
LTSA-T67RUWETA**

**5. Typical Electrical / Optical Characteristics Curves.**

(25°C Ambient Temperature Unless Otherwise Noted)

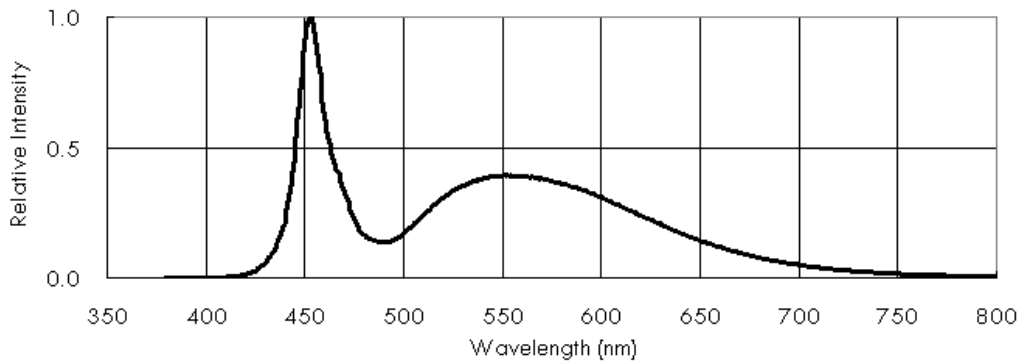

Fig.1 RELATIVE INTENSITY VS. WAVELENGTH

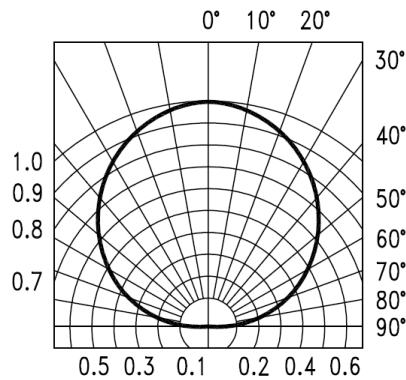

Fig. 2 SPATIAL DISTRIBUTION

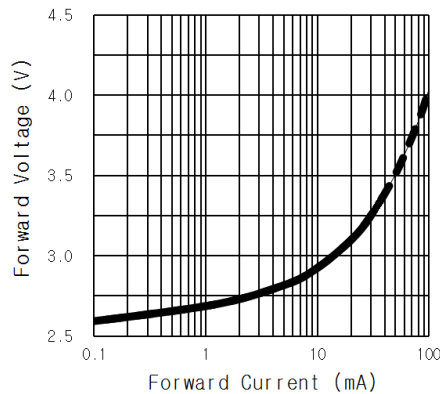

Fig. 3 FORWARD VOLTAGE V.S. FORWARD CURRENT

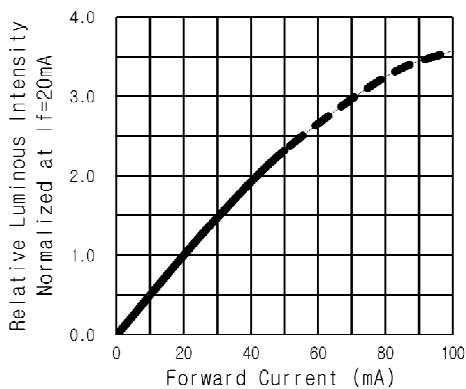

Fig. 4 RELATIVE LUMINOUS INTENSITY V.S. FORWARD CURRENT

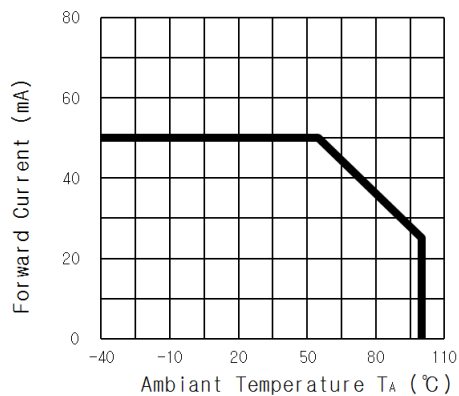

Fig.5 FORWARD CURRENT DERATING CURVE





**SMD LED  
LTSA-T67RUWETA**

6.4 Package Dimensions of Reel

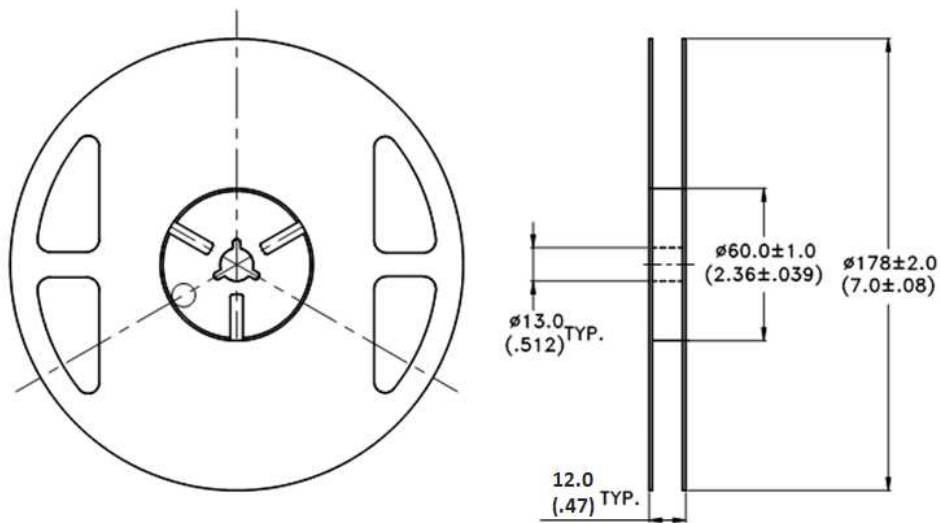

Notes:

1. Empty component pockets sealed with top cover tape.
2. 7 inch reel 2000 pieces per reel.
3. The maximum number of consecutive missing lamps is two.
4. In accordance with ANSI/EIA 481 specifications.

## SMD LED LTSA-T67RUWETA

### 7. Cautions

#### 7.1 Application

The LEDs described here are intended to be used for ordinary electronic equipment (such as office equipment, communication equipment and household applications). Consult Liteon's Sales in advance for information on applications in which exceptional reliability is required, particularly when the failure or malfunction of the LEDs may directly jeopardize life or health (such as in aviation, transportation, traffic control equipment, medical and life support systems and safety devices).

#### 7.2 Storage

This product is qualified as Moisture sensitive Level 2a per JEDEC J-STD-020 Precaution when handling this moisture sensitive product is important to ensure the reliability of the product.

The package is sealed:

The LEDs should be stored at 30°C or less and 70%RH or less. And the LEDs are limited to use within one year, while the LEDs is packed in moisture-proof package with the desiccants inside.

The package is opened:

The storage ambient for the LEDs should not exceed 30°C temperature and 60% relative humidity.

It is recommended that LEDs out of their original packaging are IR-reflowed within 4 weeks.

For extended storage out of their original packaging, it is recommended that the LEDs be stored in a sealed container with appropriate desiccant, or in a desiccators with nitrogen ambient.

LEDs stored out of their original packaging for more than 4 weeks should be baked at about 60 °C for a t least 48 hours before solder assembly.

#### 7.3 Cleaning

Use alcohol-based cleaning solvents such as isopropyl alcohol to clean the LED if necessary.

#### 7.4 Soldering

Recommended soldering conditions:

Reflow soldering		Soldering iron	
Pre-heat	150~200°C	Temperature	300°C Max.
Pre-heat time	120 sec. Max.	Soldering time	3 sec. Max. (one time only)
Peak temperature	260°C Max.		
Soldering time	10 sec. Max.(Max. two times)		

#### Notes:

Because different board designs use different number and types of devices, solder pastes, reflow ovens, and circuit boards, no single temperature profile works for all possible combinations.

However, you can successfully mount your packages to the PCB by following the proper guidelines and PCB-specific characterization.

LITE-ON Runs both component-level verification using in-house **KYRAMX98** reflow chambers and board-level assembly.

The results of this testing are verified through post-reflow reliability testing. Profiles used at LITE-ON are based on JEDEC standards to ensure that all packages can be successfully and reliably surface mounted.

Figure on page3 shows a sample temperature profile compliant to JEDEC standards. You can use this example as a

## SMD LED LTSA-T67RUWETA

generic target to set up your reflow process. You should adhere to the JEDEC profile limits as well as specifications and recommendations from the solder paste manufacturer to avoid damaging the device and create a reliable solder joint.

### 7.5 Drive Method

A LED is a current-operated device. In order to ensure intensity uniformity on multiple LEDs connected in parallel in an application, it is recommended that a current limiting resistor be incorporated in the drive circuit, in series with each LED as shown in Circuit A below.

**Circuit model A**

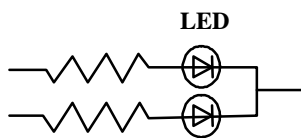

**Circuit model B**

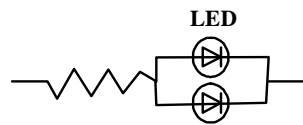

(A) Recommended circuit.

(B) The brightness of each LED might appear different due to the differences in the I-V characteristics of those LEDs.

### 7.6 ESD (Electrostatic Discharge)

Static Electricity or power surge will damage the LED.

Suggestions to prevent ESD damage:

- Use of a conductive wrist band or anti-electrostatic glove when handling these LEDs.
- All devices, equipment, and machinery must be properly grounded.
- Work tables, storage racks, etc. should be properly grounded.
- Use ion blower to neutralize the static charge which might have built up on surface of the LED's plastic lens as a result of friction between LEDs during storage and handling.

ESD-damaged LEDs will exhibit abnormal characteristics such as high reverse leakage current, low forward voltage, or "no lightup" at low currents.

To verify for ESD damage, check for "lightup" and  $V_f$  of the suspect LEDs at low currents.

The  $V_f$  of "good" LEDs should be  $>2.0V@0.1mA$  for InGaN product and  $>1.4V@0.1mA$  for AlInGaP product.

## SMD LED LTSA-T67RUWETA

### 8. Reliability Test

#### 8.1 Test Item/Condition:

No.	Test item	Test condition	# of Lots	Sample size Per Lot	Reference standard
2	Pre-conditioning	MSL 2a 125°C, 24 hrs baking Moisture Soak 60°C/60% 168 hrs Interval: 15mins ~ 4 hours to do IR-Reflow	3	462	JESD22 A-113
5b+	High Temperature Forward Bias (HTFB)	Ta=55 ± 2°C IF: 50mA 1000 hrs	3	77	JESD22 A-108
5b	High Temperature Forward Bias (HTFB)	Ta=100 ± 2°C IF: 25mA 1000 hrs	3	77	JESD22 A-108
7	Temperature Cycle (TC)	-40°C(+0, -10) to 100°C(+15,-0) 10 min 10 min 10 min 1000 cycles	3	77	JESD22 A-104
9a	High Temperature High Humidity Bias (HTHHB)	Ta=85 ± 2°C, 85 ± 5% RH IF: 35mA 1000 hrs	3	77	JESD22 A-101
10alt	Power and Temperature Cycle (PTC)	-40°C (+0, -10) to 85°C (+10,-0) 10 min 20 min 10 min IF: 35mA 1 cycle: 2 min. on / 2 min. off 15000 cycles (1000 hrs)	3	77	JESD22 A-105
11	ESD Characterization	HBM 2000V, CDM 1000V	1	30 each HBM/CDM	AEC Q101-001, and Q101-005
20	Resistance to Solder Heat	Tsld=260°C, 10sec. 3times	1	30	JESD22A-111
21	Solderability	Tsld = 235± 5°C, 5sec, Leas-free Solder	1	10	J-STD-002 JESD22B102

Note: ESD characterization is only for reference.

## 9. Others

The appearance and specifications of the product may be modified for improvement without prior notice.

## 10. Suggested Checking List

### Training and Certification

1. Everyone working in a static-safe area is ESD-certified?
2. Training records kept and re-certification dates monitored?

### Static-Safe Workstation & Work Areas

1. Static-safe workstation or work-areas have ESD signs?
2. All surfaces and objects at all static-safe workstation and within 1 ft measure less than 100V?
3. All ionizer activated, positioned towards the units?
4. Each work surface mats grounding is good?

### Personnel Grounding

1. Every person (including visitors) handling ESD sensitive (ESDS) items wears wrist strap, heel strap or conductive shoes with conductive flooring?
2. If conductive footwear used, conductive flooring also present where operator stand or walk?
3. Garments, hairs or anything closer than 1 ft to ESD items measure less than 100V\*?
4. Every wrist strap or heel strap/conductive shoes checked daily and result recorded for all DLs?
5. All wrist strap or heel strap checkers calibration up to date?

Note: \*50V for InGaN LED.

### Device Handling

1. Every ESDS items identified by EIA-471 labels on item or packaging?
2. All ESDS items completely inside properly closed static-shielding containers when not at static-safe workstation?
3. No static charge generators (e.g. plastics) inside shielding containers with ESDS items?
4. All flexible conductive and dissipative package materials inspected before reuse or recycles?

### Others

1. Audit result reported to entity ESD control coordinator?
2. Corrective action from previous audits completed?
3. Are audit records complete and on file?