

Optical Sensor
Product Data Sheet
LTR-X130P

Spec No. :DS86-2020-0021
Effective Date: 03/24/2023
Revision: A

LITE-ON DCC

RELEASE

BNS-OD-FC001/A4



Data Sheet

Optical Sensor LTR-X130P

1. Description

The LTR-X130P is an integrated low voltage I2C proximity sensor (PS), with built-in emitter in a single miniature chip lead-free surface mount package.

The PS offers a feature to detect object at user configurable distance up to 10cm, it also provides excellent ambient light suppression under 100k lux direct sunlight. The sensor has a programmable interrupt with hysteresis to response to events and that removes the need to poll the sensor for a reading which improves system efficiency. This CMOS design and factory-set one time trimming capability ensure minimal sensor-to-sensor variations for ease of manufacturability to the end customers.

2. Features

- I²C interface (Standard mode @100kHz or Fast mode @400kHz)
- Ambient Light and Proximity Sensing in one ultra-small ChipLED package
- Very low power consumption with sleep mode capability suited for battery operated devices
- Operating voltage ranges: 1.7V to 3.6V
- Operating temperature ranges: -40 to +85 °C
- Built-in temperature compensation circuit
- Programmable interrupt function for PS with adjustable upper and lower thresholds
- RoHS and Halogen free compliant
- Fast Response Time

PS Features

- Built-in LED driver and detector
- High ambient light suppression
- 8 , 9, 10, 11-bit(selectable) effective resolution
- Cancellation of crosstalk
- Programmable LED drive settings
- Programmable Interrupt

3. Applications

- Control brightness of display panel
- Object detection in mobile, computing, and consumer devices.

4. Ordering Information

Part Number	Packaging Type	Package	Quantity
LTR-X130P	Tape and Reel	8-pin chiplid package	8000

5. Outline Dimensions

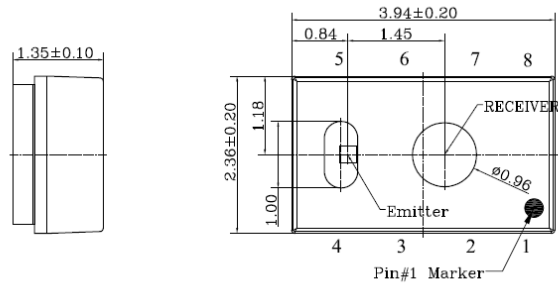

Pin-Out Assignment:

1. SDA	5. LEDA
2. INT	6. GND
3. LDR	7. SCL
4. LEDK	8. VDD

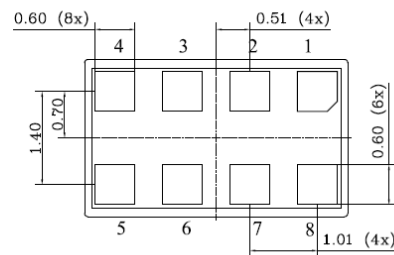
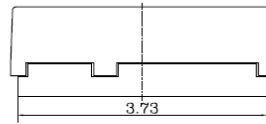

Note: 1. All dimension in millimeter.

2. All dimension tolerance is 0.2mm unless specified.

6. Functional Block Diagram

LTR-X130P contains 2 photodiodes (Visible and IR diode) for respective photocurrent measurement. The photodiode currents are converted to digital values by ADCs. The sensor also included an emitter LED, as well as some peripheral circuits such as an internal oscillator, a current source, voltage reference, and internal fuses to store trimming information.

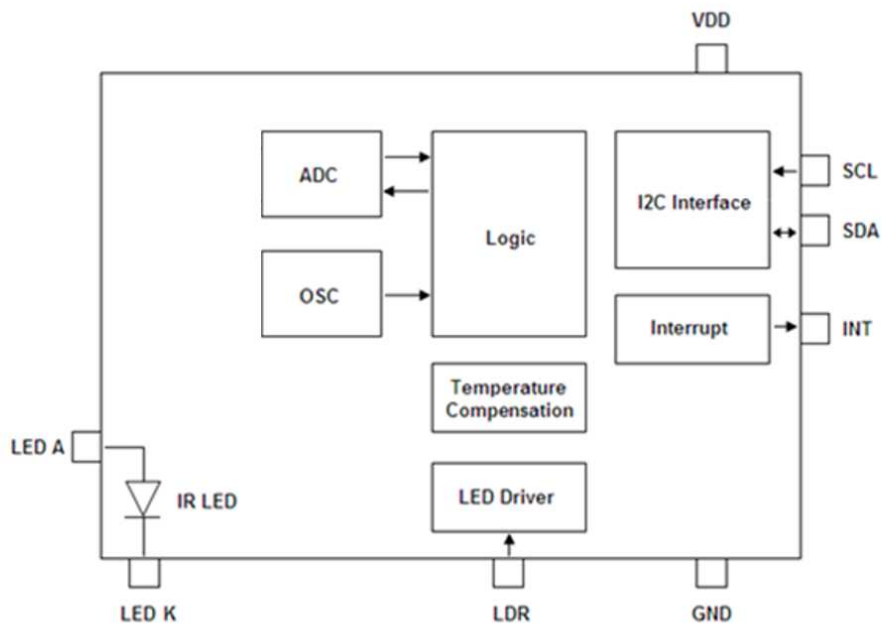

7. Application Circuit

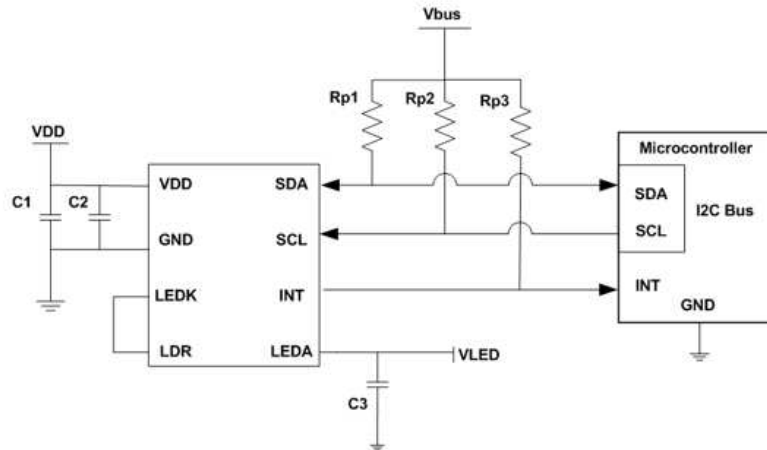

Note: It is a must that VDD and VLED to be separated.

I/O Pins Configuration Table

Pin	I/O Type	Symbol	Description
1	IN/OUT	SDA	I ² C serial data
2	OUT	INT	Interrupt
3	OUT	LDR	Connect to LED Cathode
4	OUT	LEDK	LED Cathode. Connect to LDR pin if internal LED driver circuit is used
5	IN	LEDA	LED Anode.
6	Ground	GND	Ground
7	IN	SCL	I ² C serial clock
8	Supply	VDD	Power Supply Voltage

Recommended Application Circuit Components

Component	Recommended Value
Rp1, Rp2, Rp3 [1]	1 k Ω to 10 k Ω
C1, C3	1 μ F \pm 20%, X7R / X5R Ceramic
C2	0.1 μ F

[1] Selection of pull-up resistors value is dependent on bus capacitance values. For more details, please refer to I²C Specifications: http://www.nxp.com/documents/user_manual/UM10204.pdf



Data Sheet

Optical Sensor LTR-X130P

8. Ratings and Specifications

Absolute Maximum Ratings at Ta = 25°C

Parameter	Symbol	Min.	Max	Unit
Supply Voltage	VDD		4.0	V
Digital Voltage Range	SCL, SDA, INT	-0.5	4.0	V
Max Voltage Range	LDR	-0.5	4.0	V
Storage Temperature	T _{stg}	-40	100	°C
Electrostatic Discharge Protection (Human Body Model JESD22-A114)	V _{HBM}		2000	V

Note: Exceeding these ratings could cause damage to the sensor. All voltages are with respect to ground. Currents are positive into, negative out of the specified terminal.

Recommended Operating Conditions

Description	Symbol	Min.	Typ.	Max.	Unit
Supply Voltage	VDD	1.7		3.6	V
LED Supply Voltage	V _{LED}	3		4.5	V
Interface signal input high	V _{I2Chigh}	1.5		VDD	V
Interface signal input low	V _{I2Clow}	0		0.4	V
Operating Temperature	T _{ope}	-40		85	°C

Electrical & Optical Specifications

All specifications are at VDD = 2.8V, T_{ope} = 25°C, unless otherwise noted.

Parameter	Min.	Typ.	Max.	Unit	Condition
Supply Current		95		uA	Max. duty cycle, Vdd=2.8V
Standby Current		1		uA	Shutdown Mode
Wakeup Time from Standby		5	10	ms	From Standby to Active mode where measurement can start



Data Sheet

Optical Sensor

LTR-X130P

Characteristics Proximity Sensor

Parameter	Min.	Typ.	Max.	Unit	Condition
PS Resolution	8		11	Bit	
Sensitivity Range		940		nm	
Detection Distance		10		cm	No window, 32 pulses, 60kHz, 100mA, 18% Gray Card
LED Pulse Current	2.5		125	mA	Configurable for 2.5,5,10,25,50,75,100 & 125mA
LED Pulse Frequency	60		100	kHz	
LED Duty Cycle		50		%	
Number of LED Pulses	1		255	Pulses	
Ambient Light Suppression			100	klux	Direct sunlight

Typical Device Parameter

(VDD = 2.8V, Ta=25°C, Default power-up settings, un less otherwise noted)

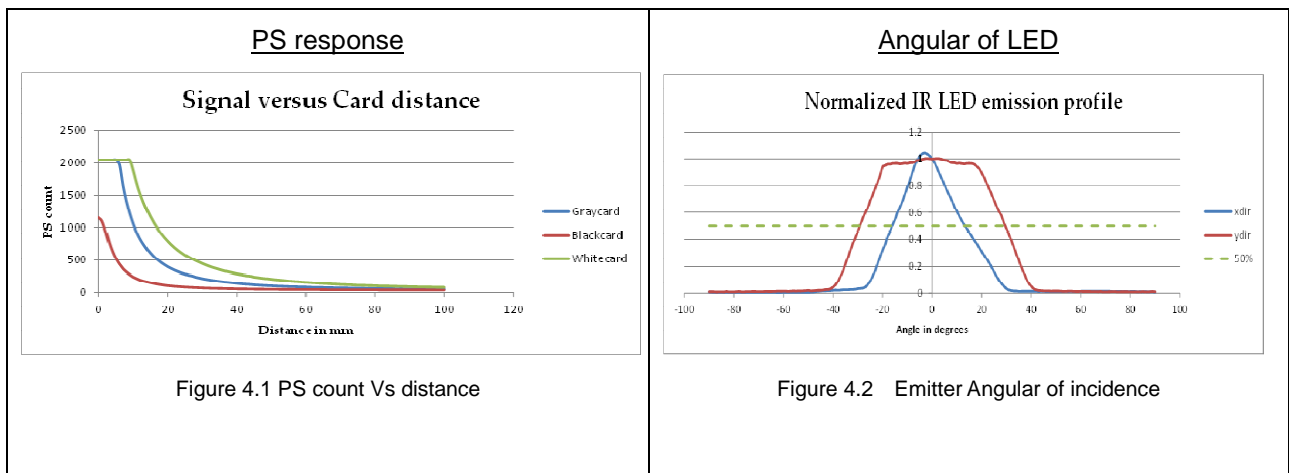

AC Electrical Characteristics

All specifications are at VBus = 1.7V, T_{ope} = 25°C, unless otherwise noted.

Parameter	Symbol	Min.	Max.	Unit
SCL clock frequency	f_{SCL}	1	400	kHz
Bus free time between a STOP and START condition	t_{BUF}	1.3		us
Hold time (repeated) START condition. After this period, the first clock pulse is generated	$t_{HD;STA}$	0.6		us
LOW period of the SCL clock	t_{LOW}	1.3		us
HIGH period of the SCL clock	t_{HIGH}	0.6		us
Set-up time for a repeated START condition	$t_{SU;STA}$	0.6		us
Set-up time for STOP condition	$t_{SU;STO}$	0.6		us
Rise time of both SDA and SCL signals	t_r	--	300	ns
Fall time of both SDA and SCL signals	t_f	--	300	ns
Data hold time	$t_{HD;DAT}$	0		us
Data setup time	$t_{SU;DAT}$	100		ns
Pulse width of spikes which must be suppressed by the input filter	t_{SP}	0	50	ns

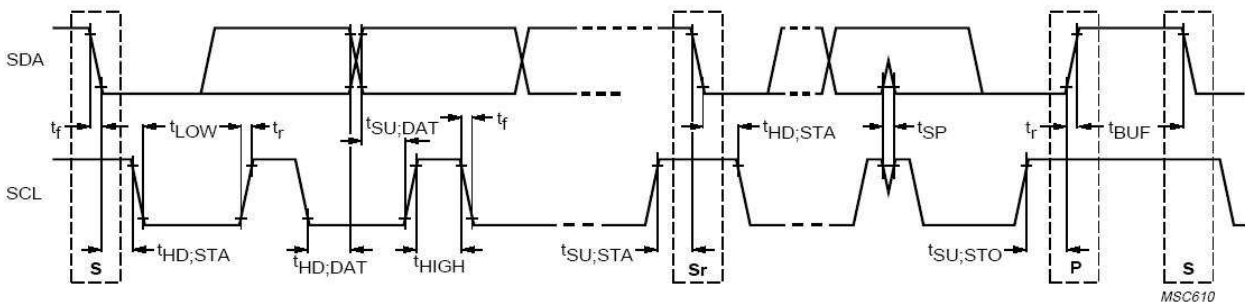

Definition of timing for I²C bus



Data Sheet

Optical Sensor

LTR-X130P

9. Principles of Operation

I²C Protocols

• I²C Write Protocol (type 1):

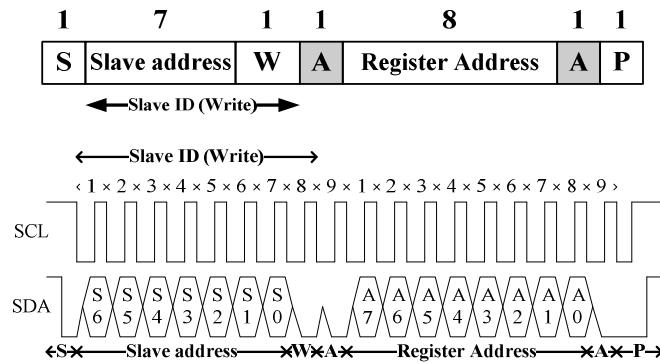

• I²C Write Protocol (type 2):

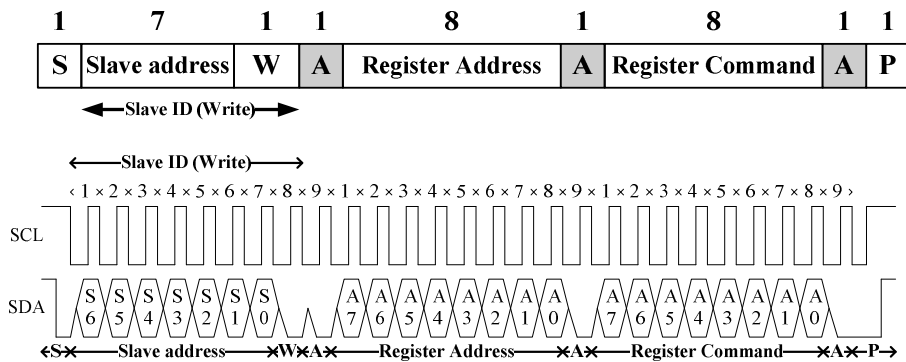

• I²C Read Protocol:

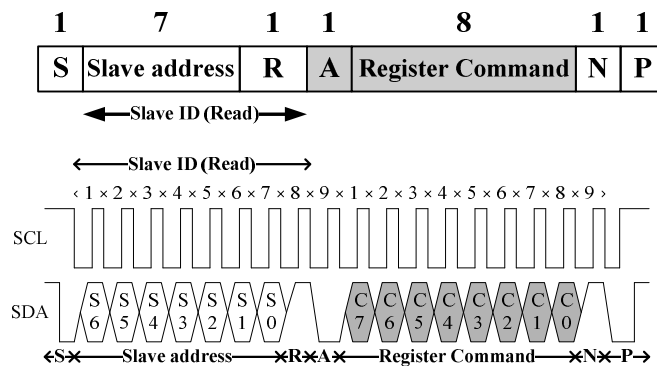





Data Sheet

Optical Sensor

LTR-X130P

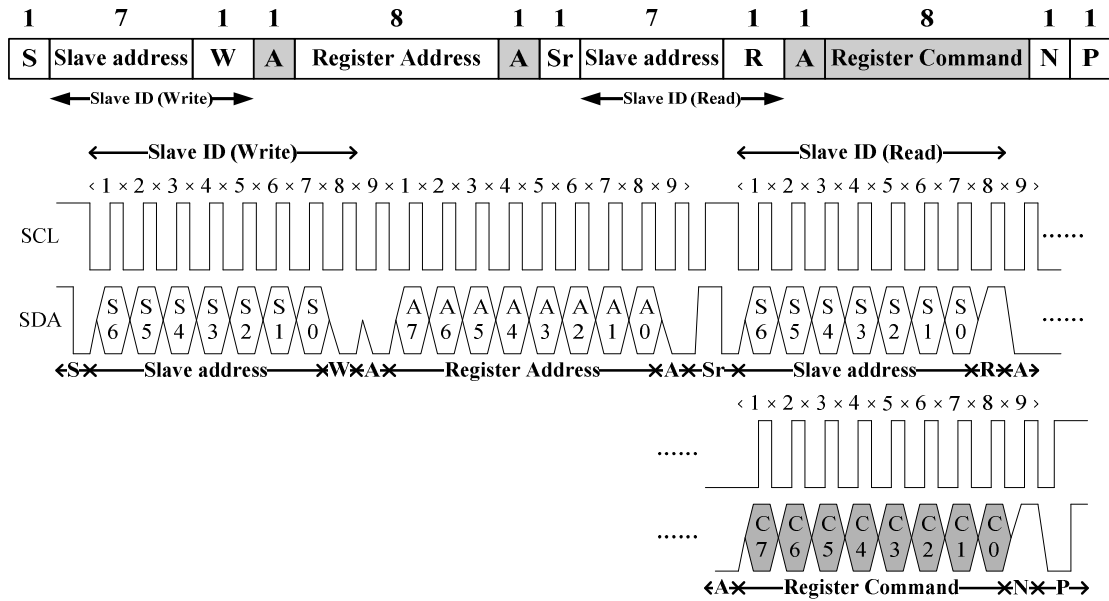
I²C Read (Combined format) Protocol:



- | | | | |
|---|----------------------------|---|--------------------------------|
| A | Acknowledge (0 for an ACK) | N | Non-Acknowledge(1 for an NACK) |
| S | Start condition | Sr | Repeated Start condition |
| P | Stop condition | | |
| W | Write (0 for writing) | R | Read (1 for read) |
|  | Slave-to-master |  | Master-to-Slave |

Notes:
1. Startup Sequence

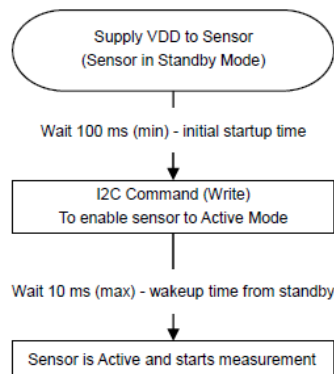



Data Sheet

Optical Sensor LTR-X130P

I²C Slave Address

The 7 bits slave address for this sensor is 0x53H. A read/write bit should be appended to the slave address by the master device to properly communicate with the sensor.

I ² C Slave Address									
Command Type	(0x53H)							W/R	value
	Bit7	Bit6	Bit5	Bit4	Bit3	Bit2	Bit1	Bit0	
Write	1	0	1	0	0	1	1	0	0xA6H
Read	1	0	1	0	0	1	1	1	0xA7H

Register Set

Addr	R / W	Register Name	Description	Reset Value
0x00	RW	MAIN_CTRL	PS operation mode control, SW reset	0x00
0x01	R/W	PS_LED	PS LED settings	0x36
0x02	R/W	PS_PULSES	PS number of LED pulses	0x08
0x03	R/W	PS_MEAS_RATE	PS measurement rate in active mode	0x45
0x06	R	PART_ID	Part number ID and revision ID	0xB1
0x07	R	MAIN_STATUS	Power-On status, Interrupt status, Data status	0x20
0x08	R	PS_DATA_0	PS measurement data, least significant bits	0x00
0x09	R	PS_DATA_1	PS measurement data, most significant bits, and overflow	0x00
0x19	R/W	INT_CFG	Interrupt configuration	0x10
0x1A	R/W	INT_PST	Interrupt persist setting	0x00
0x1B	R/W	PS_THRES_UP_0	PS interrupt upper threshold, LSB	0xFF
0x1C	R/W	PS_THRES_UP_1	PS interrupt upper threshold, MSB	0x07
0x1D	R/W	PS_THRES_LOW_0	PS interrupt lower threshold, LSB	0x00
0x1E	R/W	PS_THRES_LOW_1	PS interrupt lower threshold, MSB	0x00
0x1F	R/W	PS_CAN_0	PS intelligent cancellation level setting, LSB	0x00
0x20	R/W	PS_CAN_1	PS intelligent cancellation level setting, MSB	0x00



Data Sheet

Optical Sensor LTR-X130P

MAIN_CTRL Register (0x00) (Read/Write)

This register controls the operation modes of PS, which can be set to either standby or active mode. When writing to this register, it will cause a stop to any ongoing measurements and start new measurement.

0x00	MAIN_CTRL (default = 0x00)							
	B7	B6	B5	B4	B3	B2	B1	B0
	Reserved			Software Reset	Reserved			PS Enable

Field	Bits	Default	Description	
Reserved	7:5	000	--	--
SW Reset	4	0	0	Software reset is NOT triggered (default)
			1	Software reset is triggered
Reserved	3:1	00	--	--
PS Enable	0	0	0	PS standby(default)
			1	PS active

PS_LED Register (0x01) (Read/Write)

This register controls the LED driving current and the LED pulse modulation frequency.

0x01	PS_LED (default = 0x36)							
	B7	B6	B5	B4	B3	B2	B1	B0
	Reserved	LED Pulse Modulation Frequency			Reserved	LED Current		

Field	Bits	Default	Description	
Reserved	7	0	-	-
LED pulse	4:6	011	000	Reserved



Data Sheet

Optical Sensor
LTR-X130P

modulation Frequency			001	Reserved
			010	Reserved
			011	LED pulse period = 60kHz(default)
			100	LED pulse period = 70kHz
			101	LED pulse period = 80kHz
			110	LED pulse period = 90kHz
			111	LED pulse period = 100kHz
Reserved	3	0	-	-
LED current	2:0	110	000	LED pulsed current level = 2.5mA
			001	LED pulsed current level = 5.0mA
			010	LED pulsed current level = 10mA
			011	LED pulsed current level = 25mA
			100	LED pulsed current level = 50mA
			101	LED pulsed current level = 75mA
			110	LED pulsed current level = 100mA (default)
			111	LED pulsed current level = 125mA

PS_PULSES Register (0x02) (Read/Write)

This register controls number of PS LED pulses emitted.

0x02	PS_PULSES (default = 0x08)							
	B7	B6	B5	B4	B3	B2	B1	B0
	<i>Number of LED Pulses</i>							

Field	Bits	Default	Description	
Number of LED pulses	7:0	0000 1000	00 0000	0 pulse (no light emission)
			00 0001	1 pulse
			00 0010	2 pulses
		



Data Sheet

Optical Sensor
LTR-X130P

			00 1000	8 pulses (default)
		
			10 0000	32 pulses
			1111 1111	255 pulses

PS_MEAS_RATE Register (0x03) (Read/Write)

This register controls the timing of the periodic measurements of the PS during active mode. When the measurement rate is programmed to be faster than possible for the programmed ADC measurement, the rate will be lowered than programmed (maximum speed).

0x03	PS_MEAS_RATE (default = 0x45)							
	B7	B6	B5	B4	B3	B2	B1	B0
	0	1	0	PS Resolution/Bit Width		PS Measurement Rate		

Field	Bits	Default	Description	
Reserved	7:5	010	Must write 010	
PS Resolution/Bit Width	4:3	00	00	8 bit(default)
			01	9 bit
			10	10 bit
			11	11 bit
PS Measurement Rate	2:0	101	000	Reserved
			001	6.25ms
			010	12.5ms
			011	25 ms
			100	50ms
			101	100ms(default)
			110	200ms
			111	400ms



Data Sheet

Optical Sensor LTR-X130P

PART_ID Register (0x06) (Read Only)

This register defines the part number and revision identification of the sensor.

0x06	PART_ID (default = 0xB1)							
	B7	B6	B5	B4	B3	B2	B1	B0
	<i>Part Number ID</i>				<i>Revision ID</i>			

Field	Bits	Default	Description
Part Number ID	7:4	1011	Part Number ID
Revision ID	3:0	0001	Revision ID

MAIN_STATUS Register (0x07) (Read Only)

This register stores the information about the PS interrupts and data status. The interrupt status in Bit 1 determines if the PS interrupt criteria are met in Normal Interrupt Mode. It triggers when the PS data is above the upper or below the lower threshold for a specified number of consecutive measurements in respective interrupt persist settings. This register also provides PS logic signal status, which is used for indicating whether the detected object is near (PS data larger than PS upper threshold settings) or far (PS data smaller than PS lower threshold settings). For details interrupt behavior, refer to Section 10.

0x07	MAIN_STATUS (default = 0x20)							
	B7	B6	B5	B4	B3	B2	B1	B0
	<i>Reserved</i>		<i>Power ON Status</i>	<i>Reserved</i>		<i>PS Logic Signal Status</i>	<i>PS Interrupt Status</i>	<i>PS Data Status</i>

Field	Bits	Default	Description	
Reserved	7:6	00	--	--



Data Sheet

Optical Sensor LTR-X130P

Power On Status	5	0	0	Power on event and All interrupt threshold settings in the registers have been rest to power on default states (either due to part turned on or power supply voltage glitch). Flag is cleared after read.
Reserved	4:3	00	--	--
PS Logic Signal Status	2	0	0	Object is far (default)
			1	Object is near
PS Interrupt Status	1	0	0	Interrupt is NOT triggered (default)
			1	Interrupt is triggered and will be cleared after read
PS Data Status	0	0	0	PS data is old data (Data has been read)
			1	PS data is new data (Data has not been read and will be cleared after read)

PS_DATA Register (0x08 / 0x09) (Read Only)

The PS ADC channel data are expressed as an 11-bit data spread over 2 registers. The PS_DATA_0 and PS_DATA_1 registers provide the lower and upper byte respectively. An overflow bit is available to check if the PS data overflows. When I2C read operation is active and points to any of the register address between 0x07 and 0x18, both registers PS_DATA_0 and PS_DATA_1 will be locked until the I2C read operation has been completed or the specified address range is left. New measurement data is stored into temporary registers and the PS_DATA registers will be updated as soon as there is no on-going I2C read operation to the address range 0x07 to 0x18.

0x08	PS_DATA_0 (default = 0x00)							
	B7	B6	B5	B4	B3	B2	B1	B0
	<i>PS Data Low</i>							

0x09	PS_DATA_1 (default = 0x00)							
	B7	B6	B5	B4	B3	B2	B1	B0
	<i>Reserved</i>				<i>Overflow</i>	<i>PS Data High</i>		



Data Sheet

Optical Sensor LTR-X130P

Field	Address	Bits	Default	Description	
PS Data, Low	0x08	7:0	00000000	--	PS ADC lower byte data
Reserved	0x09	7:4	000	--	--
Overflow	0x09	3	0	0	Valid PS data (default)
				1	Overflow of PS data
PS Data, High	0x09	2:0	000	--	PS ADC upper byte data

INT_CFG Register (0x19) (Read/Write)

This register controls the operation of the interrupt pin and functions. PS have independent interrupt signal it is active low. PS interrupt is enabled by Bit 0, and it is threshold triggered based. Besides, Under Normal Interrupt Mode, the edge-triggered interrupt signal output will be maintains at active level until MAIN_STATUS register is read. While for PS Logic Output Mode, the interrupt pin output is updated after every measurement and output state is maintained between measurements.

0x19	INT_CFG (default = 0x10)							
	B7	B6	B5	B4	B3	B2	B1	B0
	Reserved						PS OUTPUT MODE	PS INT PIN ENABLE

Field	Bits	Default	Description	
Reserved	7:2	00	--	--
PS OUTPUT MODE	1	0	0	Normal Interrupt Mode: After interrupt event, INT output pin maintains active level until MAIN_STATUS register is read (default)
			1	PS Logic Output Mode: INT output pin is updated after every measurement and maintains output state between measurements.
PS Interrupt Pin Enable	0	0	0	PS interrupt Disabled (default)
			1	PS interrupt enabled



Data Sheet

Optical Sensor LTR-X130P

INT_PST Register (0x1A) (Read/Write)

This register controls the N number of times the measurement data is outside the range defined by the upper and lower threshold limits before asserting the interrupt.

0x1A	INT_PST (default = 0x00)							
	B7	B6	B5	B4	B3	B2	B1	B0
	<i>Reserved</i>				<i>PS Persist</i>			

Field	Bits	Default	Description	
Reserved	7:4	0000	--	--
PS Persist	3:0	0000	0000	Every PS value out of threshold range asserts an interrupt (default)
			0001	2 consecutive PS values out of threshold range assert an interrupt
		
			1111	16 consecutive PS values out of threshold range assert an interrupt



Data Sheet

Optical Sensor LTR-X130P

PS_THRES Register (0x1B / 0x1C / 0x1D / 0x1E) (Read/Write)

The PS_THRES_UP and PS_THRES_LOW registers determines the upper and lower limit of the interrupt threshold value respectively. Interrupt will be triggered if measurement data in PS_DATA registers is exceeding the upper and lower limits.

0x1B	PS_THRES_UP_0 (default = 0xFF)							
	B7	B6	B5	B4	B3	B2	B1	B0
	<i>PS Upper Threshold, Low</i>							

0x1C	PS_THRES_UP_1 (default = 0x07)							
	B7	B6	B5	B4	B3	B2	B1	B0
	<i>Reserved</i>					<i>PS Upper Threshold, High</i>		

0x1D	PS_THRES_LOW_0 (default = 0x00)							
	B7	B6	B5	B4	B3	B2	B1	B0
	<i>PS Lower Threshold, Low</i>							

0x1E	PS_THRES_LOW_1 (default = 0x00)							
	B7	B6	B5	B4	B3	B2	B1	B0
	<i>Reserved</i>					<i>PS Lower Threshold, High</i>		

Field	Address	Bits	Default	Description
PS Upper Threshold, Low	0x1B	7:0	11111111	PS Upper Interrupt Threshold, Low byte
Reserved	0x1C	7:3	00000	--
PS Upper Threshold, High	0x1C	2:0	111	PS Upper Interrupt Threshold, High byte
PS Lower Threshold, Low	0x1D	7:0	00000000	PS Lower Interrupt Threshold, Low byte
Reserved	0x1E	7:3	00000	--
PS Lower Threshold, High	0x1E	2:0	000	PS Lower Interrupt Threshold, High byte



Data Sheet

Optical Sensor LTR-X130P

PS_CAN Register (0x1F / 0x20) (Read/Write)

This register defines the offset compensation value for proximity offsets caused by device variations, optical crosstalk and other environment factors. This register sets the PS cancellation value to be subtracted from the measured PS data before the data is transferred to the PS_DATA registers.

0x1F	PS_CAN_0 (default = 0x00)							
	B7	B6	B5	B4	B3	B2	B1	B0
	<i>PS Cancellation Level, Low</i>							

0x20	PS_CAN_1 (default = 0x00)							
	B7	B6	B5	B4	B3	B2	B1	B0
	<i>Reserved</i>					<i>PS Cancellation Level, High</i>		

Field	Address	Bits	Default	Description
PS Cancellation Level, Low	0x1F	7:0	00000000	PS Cancellation Level, Low byte
Reserved	0x20	7:3	00000	--
PS Cancellation Level, High	0x20	2:0	000	PS Cancellation Level, High byte

10. Application Information

10.1 Device Operation (State Machine and Interrupt Features)

State Machine

Below diagram is the main state machine of LTR-X130P.

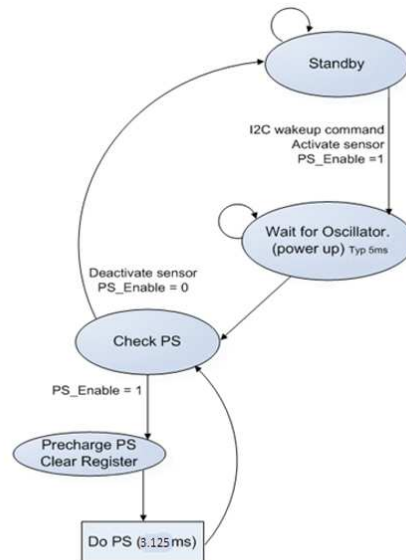

During the PS Operation, PS measurement can be activated by setting the PS_Enable bit to 1. As soon as the PS sensors become activated through an I2C command, the internal support blocks are powered on. Once the voltages and currents are settled (typically after 5ms), the state machine checks for trigger events from a measurement scheduler to start PS conversions according to the selected measurement repeat rates. Once PS_Enable is changed back to 0, a running conversion on the respective channel will be completed and the relevant ADCs and support blocks will move to power-down state.

PS Interrupt

The PS interrupt is enabled by Bit 0 (PS Interrupt Pin Enable). It triggers when the PS conversion result is above the upper or below PS threshold for a specified number of consecutive measurements set in PS Persist in INT_PST register (0x1A). The PS Logic Signal, Bit 2 of MAIN_STATUS register (0x07), is set to 0 when the PS data is below the lower PS threshold and it set to 1 if the PS data is above the upper PS threshold.

There are two options to indicate a PS interrupt signal on the INT pin: as a continuous logic signal or as an edge-triggered interrupt signal, which is cleared with the next read-out of the MAIN-STATUS register. The PS interrupt signal is also stored in MAIN_STATUS register (0x07) as flag bit in Bit 1 (PS INT Status). This status flag bit is cleared by reading the MAIN_STATUS register. The PS interrupt behavior is as shown below.

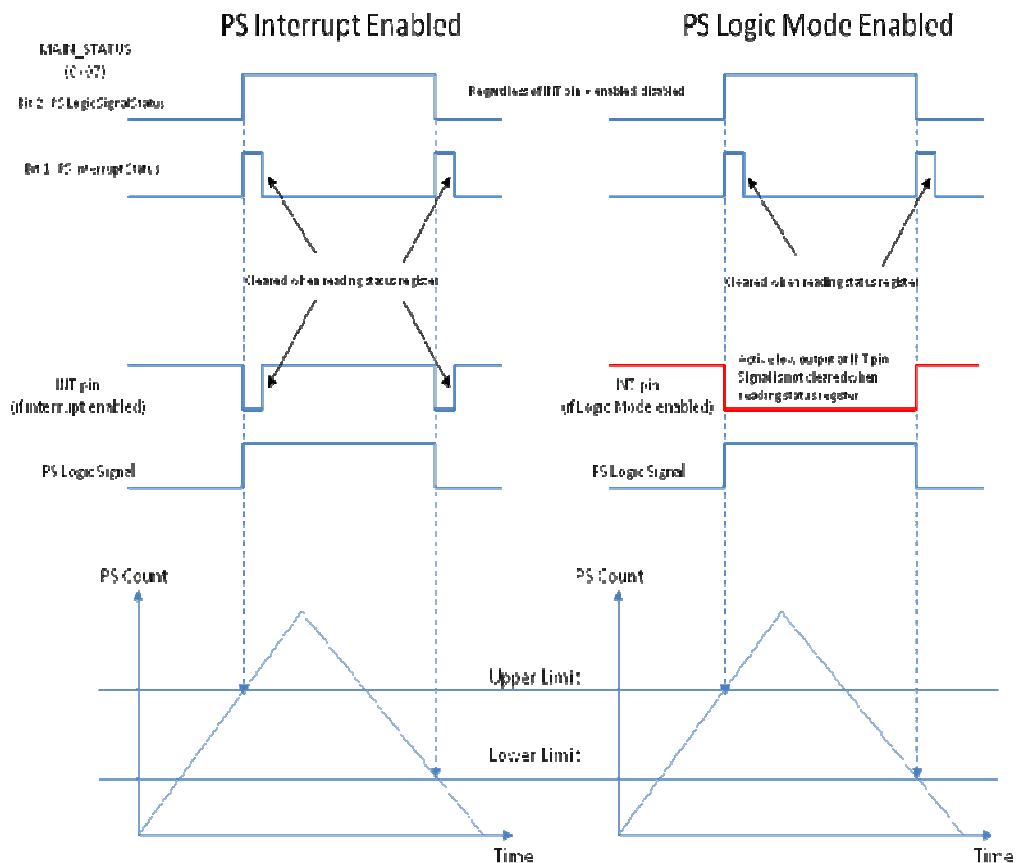



Data Sheet

Optical Sensor

LTR-X130P

11. Pseudo Codes Examples

Slave address

```
Slave_Addr = 0xA6
```

MAIN_CTRL Register

```
// This defines the operating modes of the PS
// Default settings is 0x00 (PS standby)
```

```
Register_Addr = 0x00          // MAIN_CTRL register
Command = 0x01              // PS in Active Mode,
```

```
WriteByte(Slave_Addr, Register_Addr, Command);
```

PS_LED Register

```
// This defines the LED pulse modulation frequency and Peak current.
// Default setting is 0x36 (Pulse Freq = 60kHz, peak current = 100mA).
```

```
Register_Addr = 0x01          // PS_LED register
Command = 0x36                //
                               // Command = 0x46    Pulse Freq = 60kHz, Peak Current =100mA
                               // Command = 0x44    Pulse Freq = 70kHz, Peak Current =100mA
                               // Command = 0x76    Pulse Freq = 70kHz, Peak Current = 50mA
                               // Command = 0x77    Pulse Freq = 100kHz, Peak Current = 100mA
                               // Command = 0x77    Pulse Freq = 100kHz, Peak Current = 125mA
```

```
WriteByte(Slave_Addr, Register_Addr, Command)
```

PS_PULSES Register

```
// This controls the number of PS LED pulses emitted.
// Default setting of the register is 0x08 (8 Pulses)
```

```
Register_Addr = 0x02          // PS_PULSES register
Command = 0x08                //
                               // Command = 0x00    8 pulses
                               // Command = 0x04    0 (no light)
                               // Command = 0x04    4 pulses
                               // Command = 0x20    32 pulses
```

```
WriteByte(Slave_Addr, Register_Addr, Command)
```

PS_MEAS_RATE Register

```
//This controls the PS Resolution and measurement rate.
// Default setting of the register is 0x45 (PS Resolution = 8 bit, Measurement Rate = 100ms)
```

```
Register_Addr = 0x03          // PS_MEAS_RATE register
Command = 0x45                //
                               // Command = 0x47    Resolution = 8 bit, Meas Rate = 100ms
                               // Command = 0x5D    Resolution = 8 bit Meas Rate = 400ms
                               // Command = 0x5D    Resolution = 11 bit Meas Rate = 100ms
```

```
WriteByte(Slave_Addr, Register_Addr, Command)
```



Data Sheet

Optical Sensor LTR-X130P

MAIN_STATUS Register (Read Only)

// This Register contains the information on Interrupt, PS data status.

```
Register_Addr = 0x07 // MAIN_STATUS register address
Data = ReadByte(Slave_Addr, Register_Addr)

Power_ON_Status = Data & 0x20 // If 0x20 Part went through power-up event
// If 0x00 Normal
PS_Logic_Signal_Status = Data & 0x04 // If 0x04 Object is near
// If 0x00 Object is far
PS_Interrupt_Status = Data & 0x02 // If 0x02 Interrupt triggered
// If 0x00 Interrupt condition not fulfilled
PS_Data_Status = Data & 0x01 // If 0x01 PS data is new
// If 0x00 Old (previously read) Data
```

PS_DATA Registers (Read Only)

//The register 0x08 contains PS ADC lower byte data.
 //The register 0x09 contains PS ADC 3 bits of upper byte data and PS Overflow flag
 //These registers should be read as a group, with the lower address being read first.

```
Register_Addr = 0x08 // PS_DATA0 low byte address
Data0=ReadByte(Slave_Addr, Register_Addr) // Data= PS ADC lower byte data

Register_Addr = 0x09 // PS_DATA1 high byte address
Data=ReadByte(Slave_Addr, Register_Addr) // Data= PS ADC high byte data
Data1=Data&0x03 // Mask with 0x03 to extract data

PS_ADC_Data = (Data1 << 8) | Data0 // Shift and combine lower and upper bytes to give 11-bit PS data
Overflow_status = Data & 0x08 // If 0x08 PS Data is overflow
// If 0x00 PS Data is valid
```

CLEAR_DATA Registers (Read Only)

//The register 0x0A contains CLEAR_DATA ADC 0 lower byte data.
 //The register 0x0B contains CLEAR_DATA ADC 1 middle byte data.
 //The register 0x0C contains CLEAR_DATA ADC 2 upper byte data.
 //These registers should be read as a group, with the lower address being read first.

```
Register_Addr = 0x0A // CLEAR_DATA_0 low byte address
Data0=ReadByte(Slave_Addr, Register_Addr)
Register_Addr = 0x0B // CLEAR_DATA_1 middle byte address
Data1=ReadByte(Slave_Addr, Register_Addr)
Register_Addr = 0x0C // CLEAR_DATA_2 upper byte address
Data2=ReadByte(Slave_Addr, Register_Addr)
CLEAR_Data =(Data2<<16)| (Data1 << 8) | Data0
// Shift and combine all register data to get CLEAR ADC Data
```

INT_CFG Register

//This register controls the operation of the interrupt pins and options to trigger interrupt for PS.
 //The default value for this INT_CFG register is 0x10 (Interrupts inactive for both PS)

```
Register_Addr = 0x19 // INT_CFG Register address
Command = 0x15 // Interrupt Enable
// Command = 0x17 // PS Logic Output Mode; PS Interrupt Enable
//
```



Data Sheet

Optical Sensor

LTR-X130P

```

// Command = 0x05
//                               Normal Trigger Mode; PS Interrupt Enable
// Command = 0x14
//                               Normal Trigger Mode; PS Interrupt Disable
// Command = 0x11
//                               Normal Trigger Mode; PS Interrupt Enable

```

WriteByte(Slave_Addr, Register_Addr, Command)

INTERRUPT_PERSIST Register

```

// This register sets the PS persist level.
// The default setting is 0x00. Interrupt at every PS reading outside set thresholds.

```

```

Register_Addr = 0x1A    // INT_PST register
Command = 0x00         // Interrupt for every PS value outside threshold
                       // Command = 0x10    Subsequent every PS value, outside threshold range
                       // Command = 0x11    Subsequent 2 PS values, outside threshold range
                       // Command = 0x35    Subsequent 6 PS values, outside threshold range

```

WriteByte(Slave_Addr, Register_Addr, Command)

PS_THRES Registers

```

// The register 0x1B contains PS Interrupt upper threshold lower byte data (PS_THRES_UP_0)
// The register 0x1C contains PS Interrupt upper threshold upper byte data (PS_THRES_UP_1)
// The register 0x1D contains PS Interrupt lower threshold lower byte data (PS_THRES_LOW_0)
// The register 0x1E contains PS Interrupt lower threshold upper byte data (PS_THRES_LOW_1)

```

```

// To set PS Upper threshold for Interrupt
Upper_Threshold_Value=1000 // Example 1000
Data1 = Upper_Threshold_Value >> 8 // Shift right to extract the upper byte
Data0 = Upper_Threshold_Value & 0xFF // Mask to extract lower byte.
Register_Addr = 0x1B // PS_THRES_UP_0 Register address
WriteByte(Slave_Addr, Register_Addr, Data0)
Register_Addr = 0x1C // PS_THRES_UP_1 Register address
WriteByte(Slave_Addr, Register_Addr, Data1)

```

```

// To set PS Lower threshold for Interrupt
Lower_Threshold_Value=100 // Example 100
Data1 = Lower_Threshold_Value >> 8 // Shift right to extract the upper byte
Data0 = Lower_Threshold_Value & 0xFF // Mask to extract lower byte.
Register_Addr = 0x1D // PS_THRES_LOW_0 Register address
WriteByte(Slave_Addr, Register_Addr, Data0)
Register_Addr = 0x1E // PS_THRES_LOW_1 Register address
WriteByte(Slave_Addr, Register_Addr, Data1)

```

PS_CAN Registers

```

//The register 0x1F contains PS cancellation lower byte data (PS_CAN_0)
//The register 0x20 contains 3 bits of PS cancellation upper byte data (PS_CAN_1)

```

```

//To set PS Cancellation Value (0 to 2047)
PS_Cancel_Value=100 // Example 100
Data1 = PS_Cancel_Value >> 8 // Shift right to extract the upper byte
Data0 = PS_Cancel_Value & 0xFF // Mask to extract lower byte.
Register_Addr = 0x1F // PS_CAN_0 Register address
WriteByte(Slave_Addr, Register_Addr, Data0)
Register_Addr = 0x20 // PS_CAN_1 Register address
WriteByte(Slave_Addr, Register_Addr, Data1)

```

12. Recommended Leadfree Reflow Profile

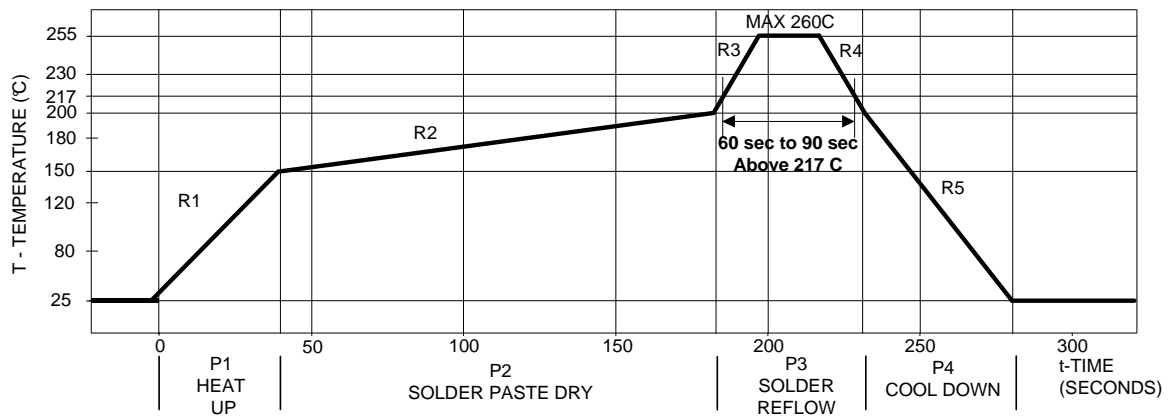

Process Zone	Symbol	ΔT	Maximum $\Delta T/\Delta \text{time}$ or Duration
Heat Up	P1, R1	25°C to 150°C	3°C/s
Solder Paste Dry	P2, R2	150°C to 200°C	100s to 180s
Solder Reflow	P3, R3	200°C to 260°C	3°C/s
	P3, R4	260°C to 200°C	-6°C/s
Cool Down	P4, R5	200°C to 25°C	-6°C/s
Time maintained above liquidus point , 217°C		> 217°C	60s to 90s
Peak Temperature		260°C	-
Time within 5°C of actual Peak Temperature		> 255°C	20s
Time 25°C to Peak Temperature		25°C to 260°C	8mins

It is recommended to perform reflow soldering no more than twice.



Data Sheet

Optical Sensor LTR-X130P

13. Moisture Proof Packaging

All LTR-X130P are shipped in moisture proof package. Once opened, moisture absorption begins. This part is compliant to JEDEC J-STD-033A Level 3.

Time from Unsealing to Soldering

After removal from the moisture barrier bag, the parts should be stored at the recommended storage conditions and soldered within seven days. When the moisture barrier bag is opened and the parts are exposed to the recommended storage conditions for more than seven days, the parts must be baked before reflow to prevent damage to the parts.

Recommended Storage Conditions

Storage Temperature	10°C to 30°C
Relative Humidity	Below 60% RH

Baking Conditions

Package	Temperature	Time
In Reels	60°C	48 hours
In Bulk	100°C	4 hours

Baking should only be done once.

14. Recommended Land Pattern and Metal Stencil Aperture

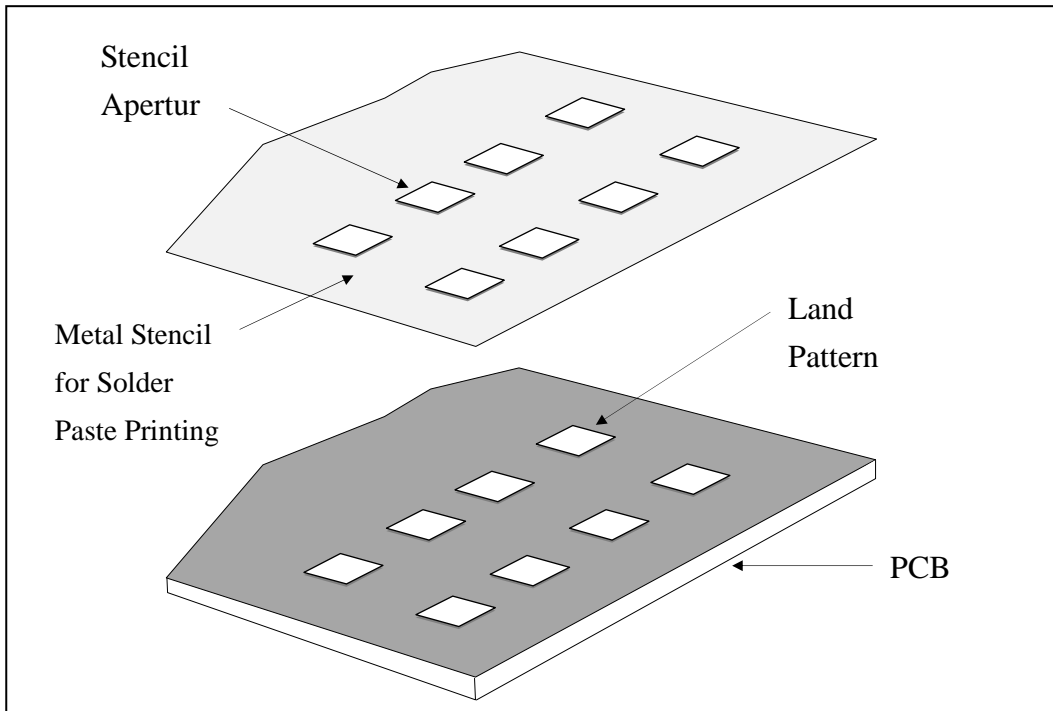

Recommended Land Pattern

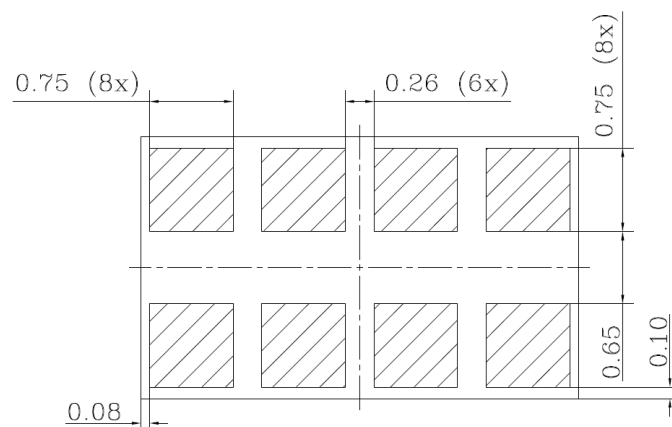

Note: All dimensions are in millimeters

Recommended Metal Stencil Aperture

It is recommended that the metal stencil used for solder paste printing has a thickness (t) of 0.11mm (0.004 inches / 4 mils) or 0.127mm (0.005 inches / 5 mils).

The stencil aperture opening is recommended to be 0.75mm x 0.75mm which has the same dimension as the land pattern. This is to ensure adequate printed solder paste volume and yet no shorting.

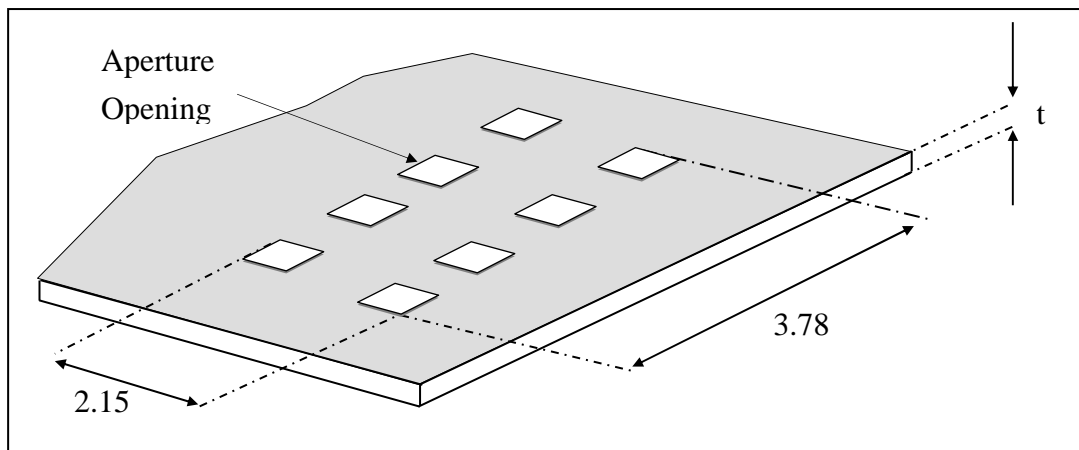

15. Package Dimension for Tape and Reel

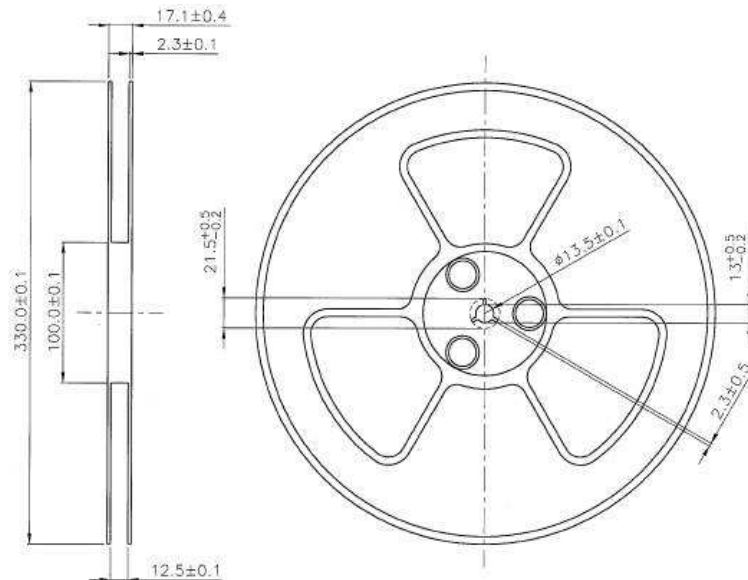
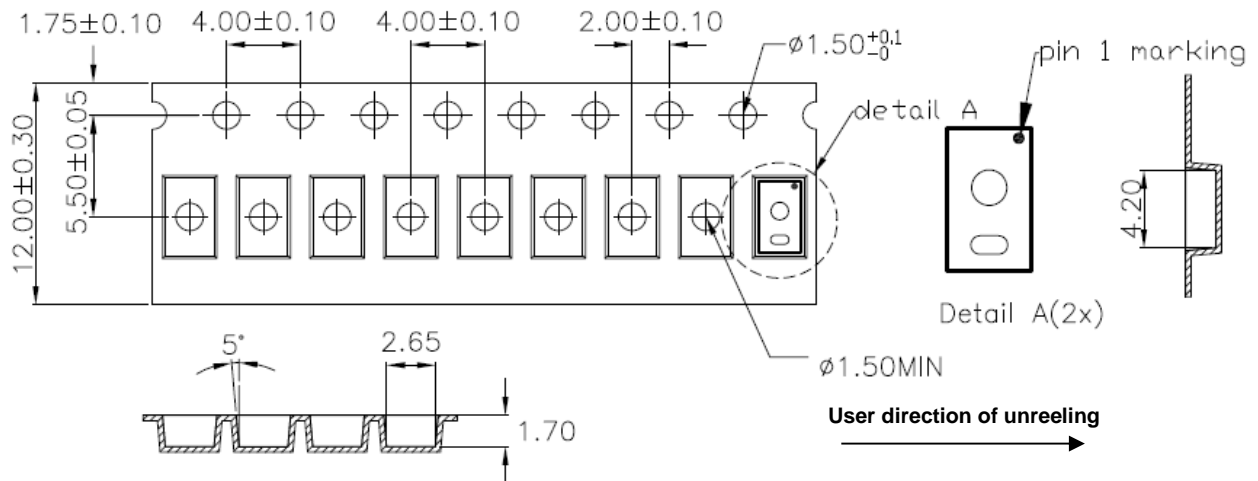

Notes:

1. All dimensions are in millimeters
2. Empty component pockets sealed with top cover tape
3. 13 inch reel - 8000 pieces per reel
4. In accordance with ANSI/EIA 481-1-A-1994 specifications



Data Sheet

Optical Sensor LTR-X130P

Revision Table:

Version	Update	Page	Date
1.0	Datasheet as created	Total 30	28-02-2020
1.1	Update Interrupt Setting	Total 30	20-02-2020