

Optical Sensor
Product Data Sheet
LTR-X100A

Spec No. :DS86-2022-0003
Effective Date: 02/08/2022
Revision: -

LITE-ON DCC

RELEASE

BNS-OD-FC001/A4

OPTICAL SENSOR LTR-X100A

Description

The LTR-X100A is an integrated low voltage I2C ambient light sensor (ALS) which offers excellent IR rejection performance, low power consumption, high accuracy under low lux environment (0-5 lux) and fast integration time in a single 2x2mm miniature chipled lead-free surface mount package.

An IR Rejection feature is uniquely implemented to improve accuracy and performance under IR environment which make it a perfect solution for indoor/outdoor application such as surveillance camera, doorbell etc.

Features

- IR Rejection Capability
- High Accuracy in low ambient brightness environment.
- Fast Responses Time
- Count stability across temperature range
- I²C interface (Standard mode @100kHz or Fast mode @400kHz)
- Ultra-small chipled package
- Very low power consumption with sleep mode capability suited for battery operated devices
- Operating voltage ranges: 1.7V to 3.6V
- Operating temperature ranges: -40 to +85 °C
- RoHS and Halogen free compliant
- 16 to 20 bits effective resolution
- Automatic rejection for 50Hz/60Hz lighting flicker

Application

Brightness Control/Detection in Surveillance Cameras, IP Camera, Door Bell and Door Camera.

Ordering Information

Part Number	Packaging Type	Package	Quantity
LTR-X100A	Tape and Reel	6-pin chipled package	2500

OPTICAL SENSOR LTR-X100A

1. Outline Dimensions

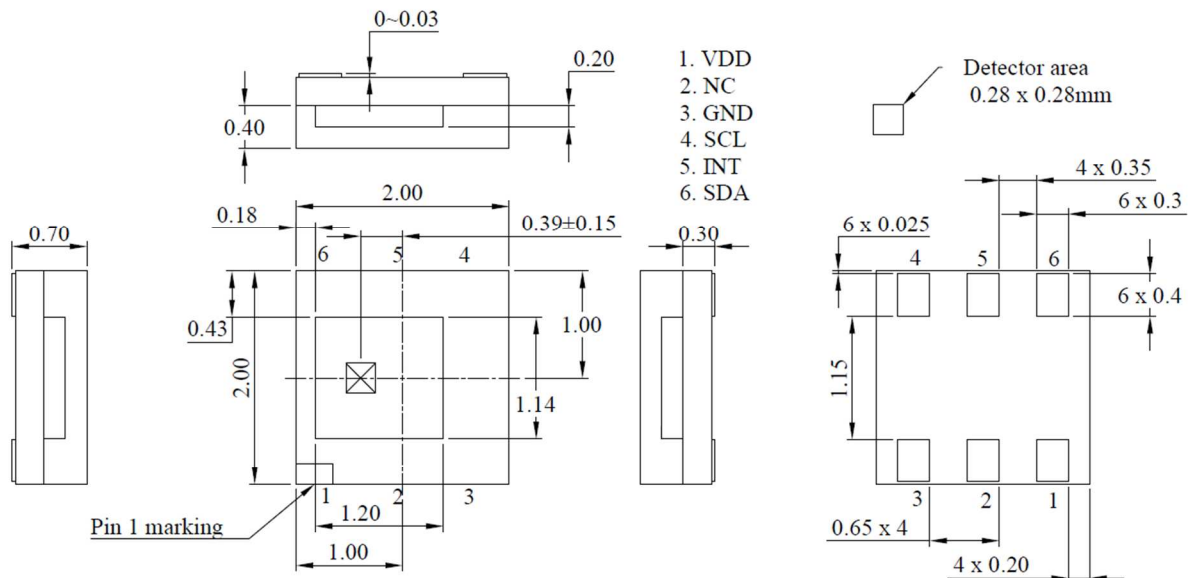

1. All dimensions in mm
2. Tolerances is +/-0.2
3. LTC reserve the right to to change the drawing till final datasheet release

I/O Pins Configuration Table

Pin	I/O Type	Symbol	Description
1		VDD	Power Supply Voltage
2		NC	No connection to this pin
3		GND	Ground
4	I	SCL*	I ² C serial clock. This pin is an open drain input.
5	O	INT*	Level Interrupt Pin. This pin is an open drain output.
6	I/O	SDA*	I ² C serial data. This pin is an open drain input / output.

OPTICAL SENSOR LTR-X100A

2. Functional Block Diagram

LTR-X100A contains photodiode for respective photocurrent measurement. The photodiode currents are converted to digital values by ADCs. The sensor also includes some peripheral circuits such as an internal oscillator, a current course and voltage reference.

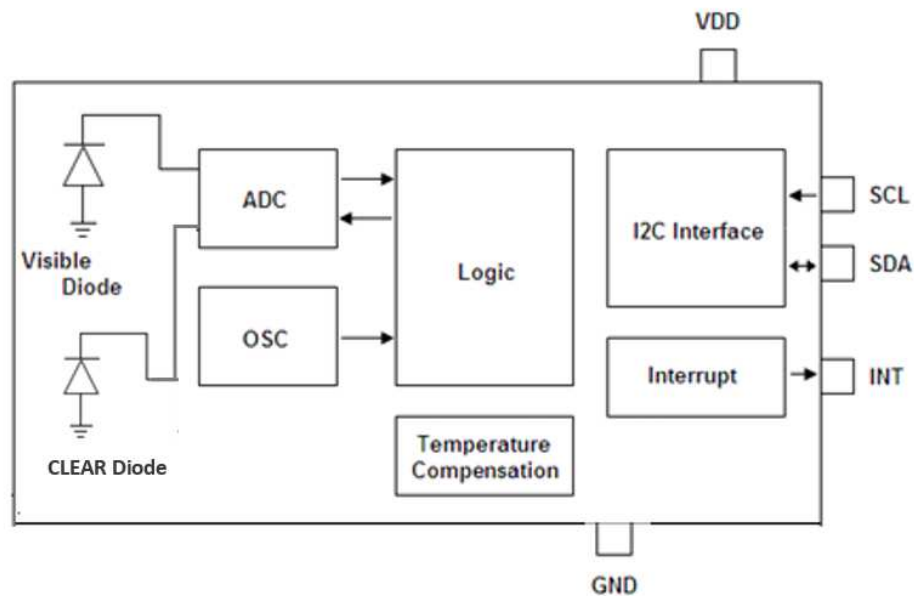

OPTICAL SENSOR LTR-X100A

3. Rating and Specification

3.1. Absolute Maximum Rating at Ta=25°C

Parameter	Symbol	Min.	Max.	Unit
Supply Voltage	VDD		4.0	V
Digital Voltage Range	SCL, SDA, INT	-0.5	4.0	V
Storage Temperature	T _{stg}	-40	100	°C
Electrostatic Discharge Protection (Human Body Model JESD22-A114)	V _{HBM}		2000	V

Note: Exceeding these ratings could cause damage to the sensor. All voltages are with respect to ground. Currents are positive into, negative out of the specified terminal.

3.2. Recommended Operating Conditions

Description	Symbol	Min.	Typ.	Max.	Unit
Supply Voltage	VDD	1.7		3.6	V
Interface signal input high	V _{I2Chigh}	1.5		VDD	V
Interface signal input low	V _{I2Clow}	0		0.4	V
Operating Temperature	T _{ope}	-40		85	°C

3.3. Electrical Specifications (VDD = 1.8V, Ta=25°C, unless otherwise noted)

Parameter	Min.	Typ.	Max.	Unit	Condition
Active Supply Current		60		µA	Integration Time = 25ms, Gain = 18, Vdd = 3V, Measurement Rate = 500ms.
Standby Current		1		µA	Shutdown Mode
Wakeup Time from Standby		5	10	ms	From Standby to Active mode where measurement can start
Reset Time (Delay time needed after SW reset)	1			ms	Delay time until the next command

3.4. Characteristics Ambient Light

Parameter	Min.	Typ.	Max.	Unit	Condition
ALS Resolution	16		20	Bit	Programmable to 16, 17, 18, 19, 20 Bit
ALS Gain	1		18		Programmable to 1x, 3x, 6x, 9x, 18x
Integration time	25		400	ms	With 50/60Hz Rejection. Integration time is automatically set with ALS Resolution. See register 0x04 for details.

OPTICAL SENSOR LTR-X100A

ALS Lux accuracy	-10	10	%	White LED, 5000K, Ta = 25°
Dark Level Count	0	5	Count	0 Lux, 18-bit resolution
50/60 Hz flicker noise error	-5	+5	%	
Sensitivity (White LED, CCT = 5000 K)	6.7	Count / Lux		ALS Gain = 3x, Integration Time = 100ms
Sensitivity (White LED, CCT = 5000 K)	40	Count / Lux		ALS Gain = 18x, Integration Time = 100ms
Sensitivity (White LED, CCT = 5000 K)	160	Count / Lux		ALS Gain = 18x, Integration Time = 400ms

3.5. Typical Device Parameter

(VDD = 2.8V, Ta=25°C, Default power-up settings, unless otherwise noted)

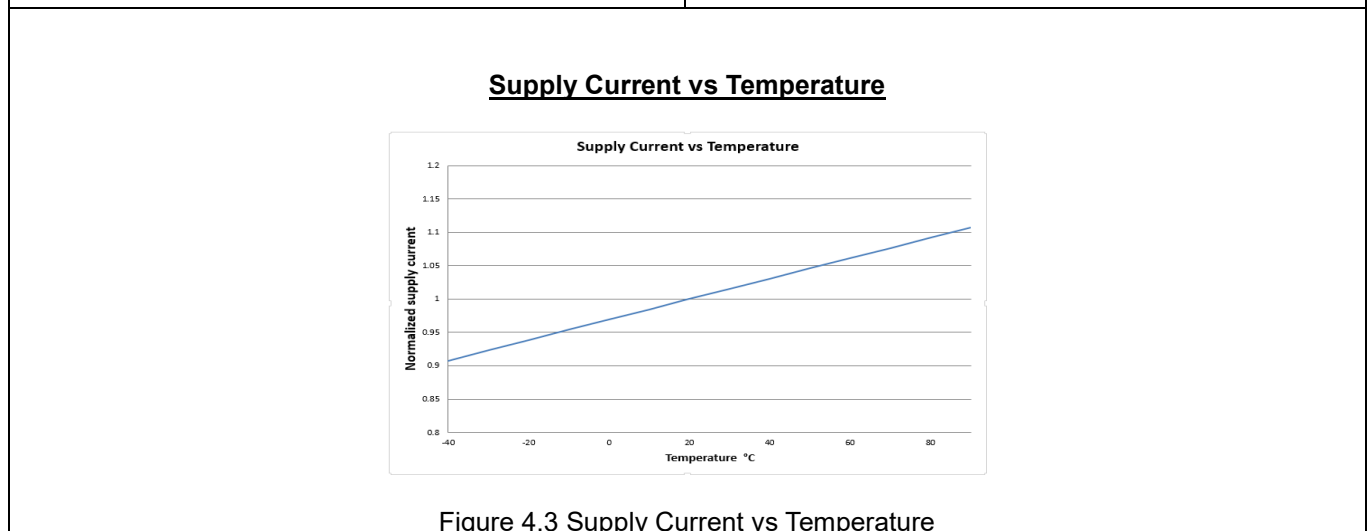
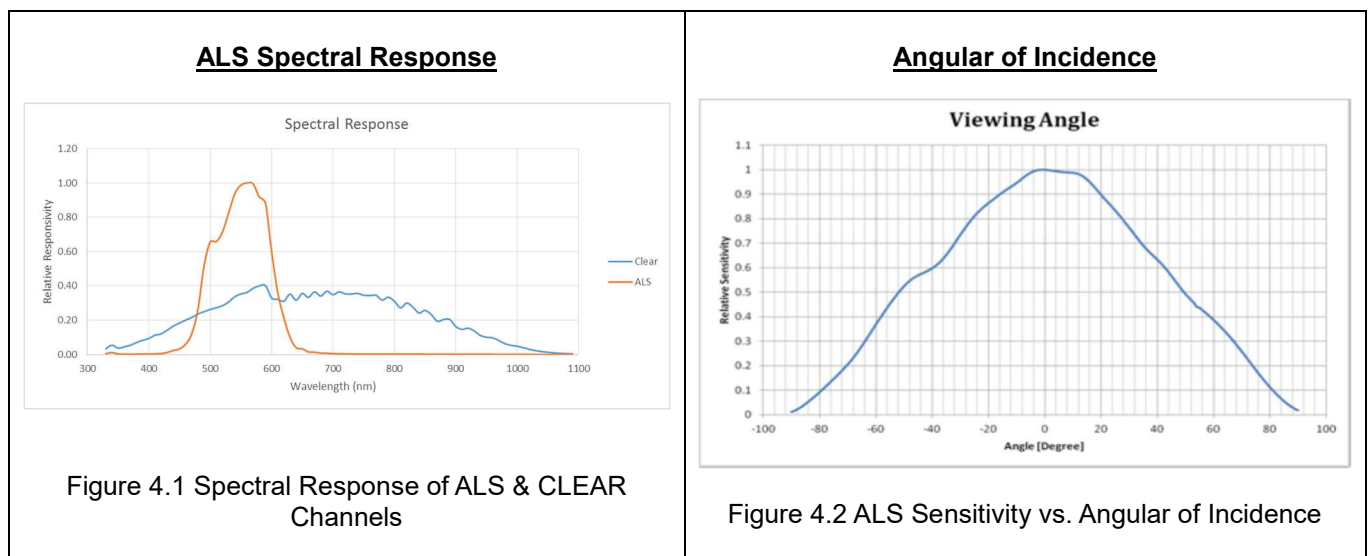

OPTICAL SENSOR LTR-X100A

3.6 AC Electrical Characteristics

All specifications are at VBus = 1.7V, T_{ope} = 25°C, unless otherwise noted.

Parameter	Symbol	Standard mode		Fast mode		Unit
		Min.	Max.	Min.	Max.	
SCL clock frequency	f_{SCL}	100		400		kHz
Bus free time between a STOP and START condition	t_{BUF}	4.7	-	1.3	-	us
Hold time (repeated) START condition. After this period, the first clock pulse is generated	$t_{HD,STA}$	4.0	-	0.6	-	us
LOW period of the SCL clock	t_{LOW}	4.7	-	1.3	-	us
HIGH period of the SCL clock	t_{HIGH}	4.0	-	0.6	-	us
Set-up time for a repeated START condition	$t_{SU,STA}$	4.7	-	0.6	-	us
Set-up time for STOP condition	$t_{SU,STO}$	4.0	-	0.6	-	us
Rise time of both SDA and SCL signals	t_r	-	1000	-	300	ns
Fall time of both SDA and SCL signals	t_f	-	300	-	300	ns
Data hold time	$t_{HD,DAT}$	0	-	0	-	us
Data setup time	$t_{SU,DAT}$	250	-	100	-	ns

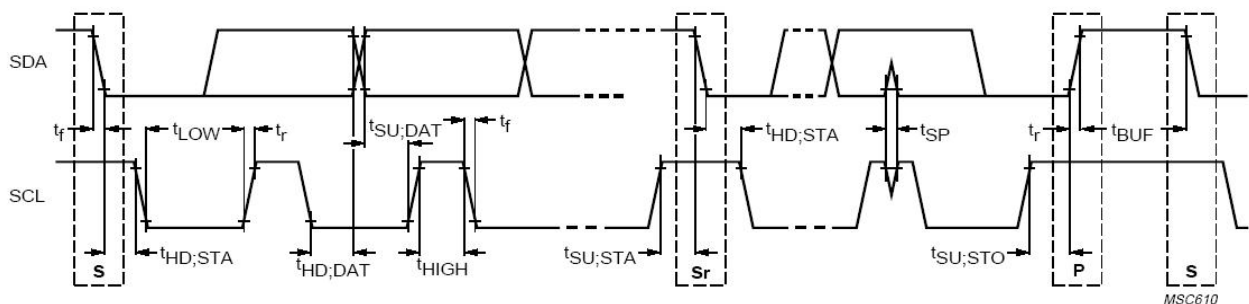

Definition of timing for I²C bus

OPTICAL SENSOR LTR-X100A

4. Principle of Operation

I²C Protocols

• I²C Write Protocol (type 1):

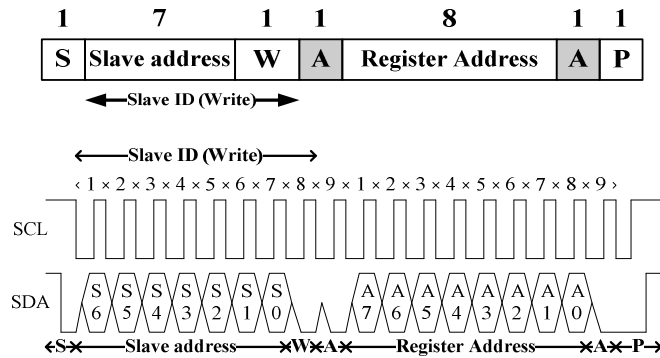

• I²C Write Protocol (type 2):

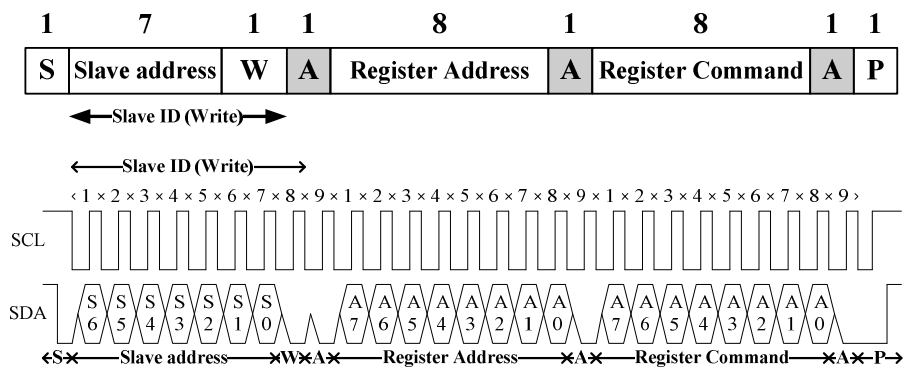

• I²C Read Protocol:

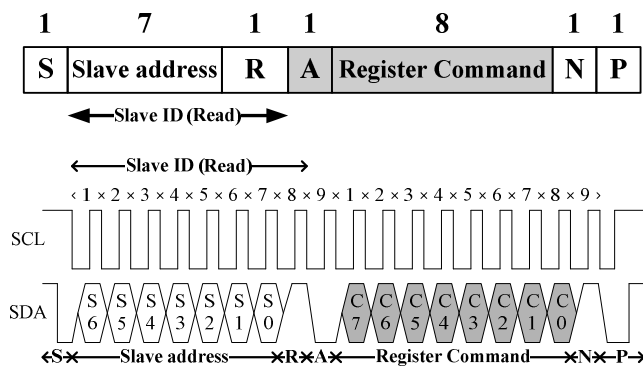

OPTICAL SENSOR LTR-X100A

· I²C Read (Combined format) Protocol:

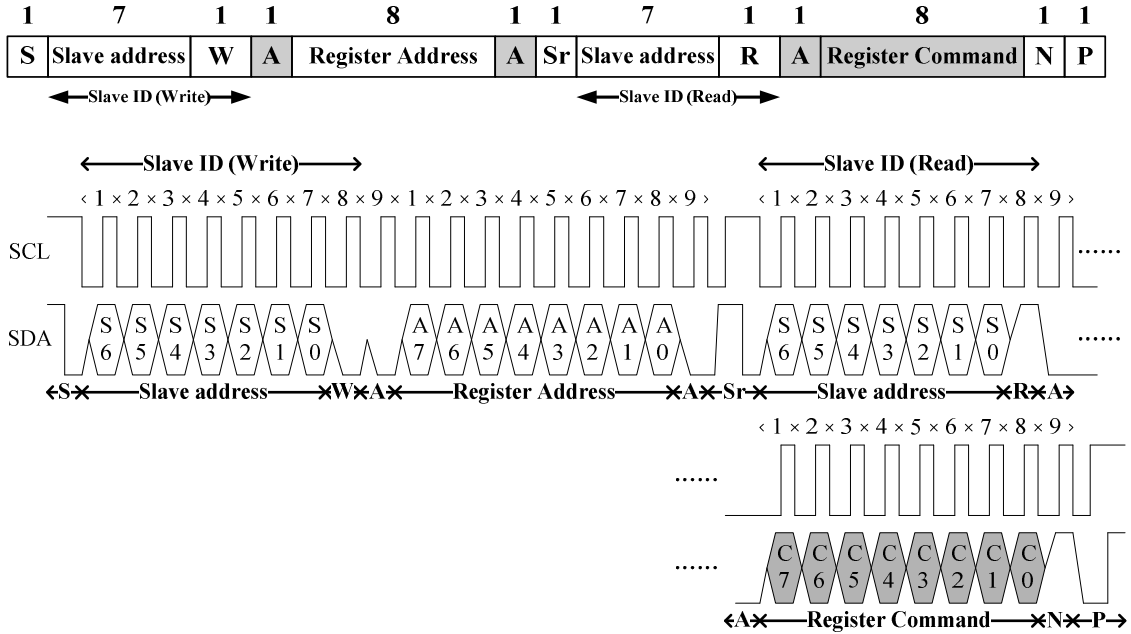

- | | |
|---|---|
| <p>A Acknowledge (0 for an ACK)</p> <p>S Start condition</p> <p>P Stop condition</p> <p>W Write (0 for writing)</p> <p> Slave-to-master</p> | <p>N Non-Acknowledge (1 for an NACK)</p> <p>Sr Repeated Start condition</p> <p>R Read (1 for read)</p> <p> Master-to-Slave</p> |
|---|---|

Notes:

1. Startup Sequence

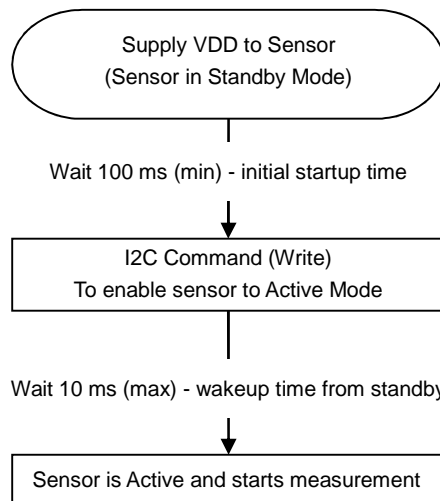

OPTICAL SENSOR LTR-X100A

I2C Slave Address

The device has a 7-bit slave address of 0x53. A read/write bit should be appended to the slave address by the master device to properly communicate with the device.

I ² C Slave Address (Default)									
Command Type	(0x53)							W/R	value
	Bit 7	Bit 6	Bit 5	Bit 4	Bit 3	Bit 2	Bit 1	Bit 0	
Write	1	0	1	0	0	1	1	0	0xA6H
Read	1	0	1	0	0	1	1	1	0xA7H

5. Register Set

Addr	R/W	Register Name	Description	Reset Value
0x00	R/W	MAIN_CTRL	ALS operation mode control, SW reset	0x00
0x04	R/W	ALS_MEAS_RES	ALS measurement rate and resolution in Active Mode	0x22
0x05	R/W	ALS_GAIN	ALS Gain Control	0x01
0x06	R	PART_ID	Part number ID and revision ID	0xB1
0x07	R	ALS_STATUS	Power-On status, Interrupt status, Data status	0x20
0x0A	R	CLEAR_DATA_0	CLEAR ADC measurement data, LSB	0x00
0x0B	R	CLEAR_DATA_1	CLEAR ADC measurement data	0x00
0x0C	R	CLEAR_DATA_2	CLEAR ADC measurement data, MSB	0x00
0x0D	R	ALS_DATA_0	ALS ADC measurement data, LSB	0x00
0x0E	R	ALS_DATA_1	ALS ADC measurement data	0x00
0x0F	R	ALS_DATA_2	ALS ADC measurement data, MSB	0x00
0x19	R/W	INT_CFG	Interrupt configuration	0x10
0x1A	R/W	INT_PST	Interrupt persist setting	0x00
0x21	R/W	ALS_THRES_UP_0	ALS interrupt upper threshold, LSB	0xFF
0x22	R/W	ALS_THRES_UP_1	ALS interrupt upper threshold, intervening bits	0xFF
0x23	R/W	ALS_THRES_UP_2	ALS interrupt upper threshold, MSB	0x0F
0x24	R/W	ALS_THRES_LOW_0	ALS interrupt lower threshold, LSB	0x00
0x25	R/W	ALS_THRES_LOW_1	ALS interrupt lower threshold, intervening bits	0x00
0x26	R/W	ALS_THRES_LOW_2	ALS interrupt lower threshold, MSB	0x00

OPTICAL SENSOR LTR-X100A

MAIN_CTRL Register (0x00) (Read/Write)

This register controls the operation modes of ALS, which can be set to either standby or active mode. When writing to this register, it will cause a stop to any ongoing measurements and start new measurement.

0x00	MAIN_CTRL (default = 0x00)							
	B7	B6	B5	B4	B3	B2	B1	B0
	Reserved			Software Reset	Reserved		ALS Enable	Reserved

Field	Bits	Default	Description	
Reserved	7:5	000	--	Must write 000
SW Reset	4	0	0	Software reset is NOT triggered (default)
			1	Software reset is triggered
Reserved	2:3	00	--	Must Write 00
ALS Enable	1	0	0	ALS standby(default)
			1	ALS active
Reserved	0	0	--	Must write 0

OPTICAL SENSOR LTR-X100A

ALS_MEAS_RES Register (0x04) (Read/Write)

This register controls ALS measurement resolution, Gain setting and measurement rate. When the measurement rate is programmed to be faster than possible for the programmed ADC measurement, the rate will be lowered than programmed (maximum speed).

0x04	ALS_MEAS_RES (default = 0x22)							
	B7	B6	B5	B4	B3	B2	B1	B0
	Reserved		ALS/C Resolution/Bit Width		Reserved		ALS Measurement Rate	

Field	Bits	Default	Description	
Reserved	7	0	Must write 0	
ALS Resolution	6:4	010	000	20 Bit, Conversion time = 400ms
			001	19 Bit, Conversion time = 200ms
			010	18 Bit, Conversion time = 100ms(default)
			011	17 Bit, Conversion time = 50ms
			100	16 Bit, Conversion time = 25ms
			101/110/111	Reserved
Reserved	3	0	--	--
ALS Measurement Rate	2:0	010	000	25ms
			001	50ms
			010	100ms (default)
			011	500ms
			101/110/111	Reserved

OPTICAL SENSOR LTR-X100A

ALS_GAIN Register (0x05) (Read/Write)

This register controls ALS measurement Gain Range.

0x05	ALS_GAIN (default = 0x01)							
	B7	B6	B5	B4	B3	B2	B1	B0
	<i>Reserved</i>					<i>ALS Gain Range</i>		

Field	Bits	Default	Description	
Reserved	7:3	00000	00000	Must write 00000
ALS Gain Range	2:0	001	000	Gain Range: 1x
			001	Gain Range: 3x (default)
			010	Gain Range: 6x
			011	Gain Range: 9x
			100	Gain Range: 18x

PART_ID Register (0x06) (Read Only)

This register defines the part number and revision identification of the sensor.

0x06	PART_ID (default = 0xB1)							
	B7	B6	B5	B4	B3	B2	B1	B0
	<i>Part Number ID</i>				<i>Revision ID</i>			

Field	Bits	Default	Description
Part Number ID	7:4	1011	Part Number ID
Revision ID	3:0	0001	Revision ID

OPTICAL SENSOR LTR-X100A

ALS_STATUS Register (0x07) (Read Only)

This register stores the information about the ALS interrupts and data status. The interrupt status in Bit 4 determines if the ALS interrupt criteria are met in Normal Interrupt Mode. It triggers when the ALS data is above the upper or below the lower threshold for a specified number of consecutive measurements in respective interrupt persist settings. For details interrupt behavior, refer to Section 10.

0x07	MAIN_STATUS (default = 0x20)							
	B7	B6	B5	B4	B3	B2	B1	B0
	Reserved		Power ON Status	ALS Interrupt Status	ALS Data Status	Reserved		

Field	Bits	Default	Description	
Reserved	7:6	00	00	Must write 00
Power On Status	5	0	0	Power on event and All interrupt threshold settings in the registers have been rest to power on default states (either due to part turned on or power supply voltage glitch). Flag is cleared after read.
ALS Interrupt Status	4	0	0	Interrupt is NOT triggered (default)
			1	Interrupt is triggered and will be cleared after read
ALS Data Status	3	0	0	ALS data is old data (Data has been read)
			1	ALS data is new data (Data has not been read and will be cleared after read)
Reserved	2:0	000	000	Must write 000

OPTICAL SENSOR LTR-X100A

CLEAR_DATA Register (0x0A / 0x0B / 0x0C) (Read Only)

The Clear Channel digital output data are expressed as a 16 to 20 bit unsigned integer data. When I2C read operation is active and points to any of the register address between 0x07 and 0x18, all 3 registers will be locked until the I2C read operation has been completed or the specified address range is left. This is to ensure that the data in the registers is from the same measurement even if an additional measurement cycle ends during the read operation. New measurement data is stored into temporary registers and the CLEAR_DATA registers will be updated as soon as there is no on-going I2C read operation to the address range 0x07 to 0x18.

0x0A	CLEAR_DATA_0 (default = 0x00)							
	B7	B6	B5	B4	B3	B2	B1	B0
	<i>CLEAR DATA, Low</i>							

0x0B	CLEAR_DATA_1 (default = 0x00)							
	B7	B6	B5	B4	B3	B2	B1	B0
	<i>CLEAR DATA, Middle</i>							

0x0C	CLEAR_DATA_2 (default = 0x00)							
	B7	B6	B5	B4	B3	B2	B1	B0
	<i>Reserved</i>				<i>CLEAR DATA, High</i>			

Field	Address	Bits	Default	Description
Clear Data, Low	0x0A	7:0	00000000	Clear Data lower byte data
Clear Data, Middle	0x0B	7:0	00000000	Clear Data Middle byte data
Clear Data, High	0x0C	7:4	0000	Reserved
		3:0	0000	Clear Data Higher byte data

OPTICAL SENSOR LTR-X100A

ALS_DATA Register (0x0D / 0x0E / 0x0F) (Read Only)

The ALS Channel digital output data are expressed as a 16 to 20 bit unsigned integer data. When I2C read operation is active and points to any of the register address between 0x07 and 0x18, all 3 registers will be locked until the I2C read operation has been completed or the specified address range is left. This is to ensure that the data in the registers is from the same measurement even if an additional measurement cycle ends during the read operation. New measurement data is stored into temporary registers and the ALS_DATA registers will be updated as soon as there is no on-going I2C read operation to the address range 0x07 to 0x18.

0x0D	ALS_DATA_0 (default = 0x00)							
	B7	B6	B5	B4	B3	B2	B1	B0
	<i>ALS DATA, Low</i>							

0x0E	ALS_DATA_1 (default = 0x00)							
	B7	B6	B5	B4	B3	B2	B1	B0
	<i>ALS DATA, Middle</i>							

0x0F	ALS_DATA_2 (default = 0x00)							
	B7	B6	B5	B4	B3	B2	B1	B0
	<i>Reserved</i>				<i>ALS DATA, High</i>			

Field	Address	Bits	Default	Description
ALS Data, Low	0x0D	7:0	00000000	ALS Data lower byte data
ALS Data, Middle	0x0E	7:0	00000000	ALS Data Middle byte data
ALS Data, High	0x0F	7:4	0000	Reserved
		3:0	0000	ALS Data Higher byte data

OPTICAL SENSOR LTR-X100A

INT_CFG Register (0x19) (Read/Write)

This register controls the operation of the interrupt pin and functions. ALS has independent interrupt signal and ALS interrupt is active low.

ALS interrupt is enabled by Bit 2. Under Normal Interrupt Mode, the edge-triggered interrupt signal output will be maintains at active level until MAIN_STATUS register is read.

0x19	INT_CFG (default = 0x10)							
	B7	B6	B5	B4	B3	B2	B1	B0
	Reserved		ALS INT SELECT		Reserved	ALS INT PIN ENABLE	Reserved	

Field	Bits	Default	Description	
Reserved	7:6	00	00	Must write 00
ALS Interrupt Select	4:5	01	00	Reserved
			01	ALS Channel(Default)
Reserved	3	0	0	Must be 0
ALS Interrupt Pin Enable	2	0	0	ALS interrupt disabled (default)
			1	ALS interrupt enabled
Reserved	1:0	00	00	Must write 00

OPTICAL SENSOR LTR-X100A

INT_PST Register (0x1A) (Read/Write)

This register controls the N number of times the measurement data is outside the range defined by the upper and lower threshold limits before asserting the interrupt.

0x1A	INT_PST (default = 0x00)							
	B7	B6	B5	B4	B3	B2	B1	B0
	<i>ALS Persist</i>				<i>Reserved</i>			

Field	Bits	Default	Description	
ALS Persist	7:4	0000	0000	Every ALS value out of threshold range asserts an interrupt (default)
			0001	2 consecutive ALS values out of threshold range assert an interrupt
			0010	3 consecutive ALS values out of threshold range assert an interrupt
		
			1111	16 consecutive ALS values out of threshold range assert an interrupt
Reserved	3:0	0000	Must write 0000	

ALS_THRES Register (0x21 / 0x22 / 0x23 / 0x24 / 0x25 / 0x26) (Read/Write)

The ALS_THRES_UP (up to 20-bits) and ALS_THRES_LOW (up to 20-bits) registers determines the upper and lower limit of the interrupt threshold value respectively. Interrupt will be triggered if measurement data in ALS_DATA is exceeding the upper and lower limits.

0x21	ALS_THRES_UP_0 (default = 0xFF)							
	B7	B6	B5	B4	B3	B2	B1	B0
	<i>ALS Upper Threshold, Low</i>							

0x22	ALS_THRES_UP_1 (default = 0xFF)							
	B7	B6	B5	B4	B3	B2	B1	B0
	<i>ALS Upper Threshold, Mid</i>							

OPTICAL SENSOR LTR-X100A

0x23	ALS_THRES_UP_2 (default = 0x0F)							
	B7	B6	B5	B4	B3	B2	B1	B0
	Reserved				ALS Upper Threshold, High			

0x24	ALS_THRES_LOW_0 (default = 0x00)							
	B7	B6	B5	B4	B3	B2	B1	B0
	ALS Lower Threshold, Low							

0x25	ALS_THRES_LOW_1 (default = 0x00)							
	B7	B6	B5	B4	B3	B2	B1	B0
	ALS Lower Threshold, Mid							

0x26	ALS_THRES_LOW_2 (default = 0x00)							
	B7	B6	B5	B4	B3	B2	B1	B0
	Reserved				ALS Lower Threshold, High			

Field	Address	Bits	Default	Description
ALS Upper Threshold, Low	0x21	7:0	11111111	ALS upper interrupt threshold, Low byte
ALS Upper Threshold, Mid	0x22	7:0	11111111	ALS upper interrupt threshold, Mid byte
ALS Upper Threshold, High	0x23	7:4	0000	Reserved
		3:0	1111	ALS upper interrupt threshold, High byte
ALS Lower Threshold, Low	0x24	7:0	00000000	ALS lower interrupt threshold, Low byte
ALS Lower Threshold, Mid	0x25	7:0	00000000	ALS lower interrupt threshold, Mid byte
ALS Lower Threshold, High	0x26	7:4	0000	Reserved
		3:0	0000	ALS lower interrupt threshold, High byte

OPTICAL SENSOR LTR-X100A

6. Application Circuit

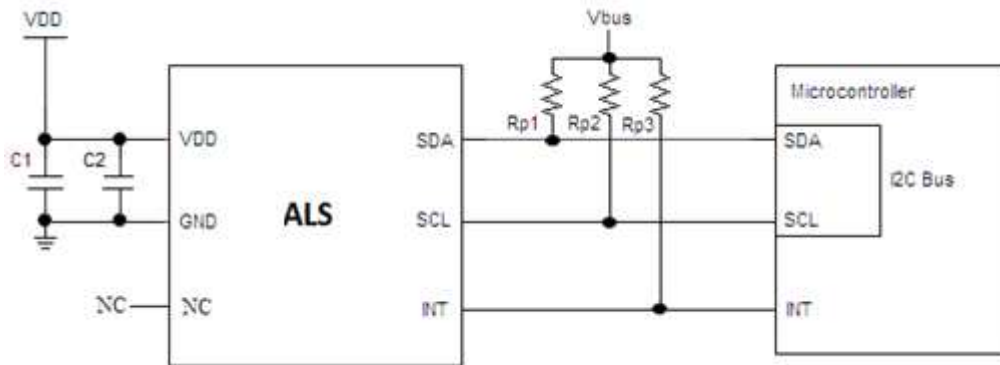

* Note: For noisy environment, add 10pF capacitor from signal to GND for additional noise filtering.

Recommended Application Circuit Components

Component	Recommended Value
Rp1, Rp2, Rp3 [1]	1 kΩ to 10 kΩ
C1	0.1uF
C2	4.7uF

Notes:

[1] Selection of pull-up resistors value is dependent on bus capacitance values. For more details, please refer to I2C Specifications: http://www.nxp.com/documents/user_manual/UM10204.pdf

OPTICAL SENSOR LTR-X100A

7. Application Information

7.1 Lux Formula

Lux_Calc is the calculated lux reading and ALS DATA is the digital representation (output ADC) of ambient light level stored in the registers (Address: 0x0D-0x0F) regardless of light sources.

For no window (Clear window)

$$Lux_{Calc} = \frac{0.45 \times ALS_{DATA}}{(GAIN \times INT)}$$

For device under window (eg: Tinted window)

Window Factor is needed when device under Window glass with coated tinted ink. This is to compensate the light loss due to the lower transmission rate of the window glass.

$$Lux_{Calc} = \frac{0.45 \times ALS_{DATA}}{(GAIN \times INT)} \times Window\ Factor$$

Where:

ALS Gain	GAIN
X1	1
X3	3
X6	6
X9	9
X18	18

Resolution (bit) / Integration Time (ms)	INT
16-bit, 25ms	0.25
17-bit, 50ms	0.5
18-bit, 100ms	1
19-bit, 200ms	2
20-bit, 400ms	4

Note :

1. For low lux detection (0.01 lux to 6500 lux, under bare die condition), it is recommended to use highest Gain (Gain x18) and highest resolution bit (20 bit).
2. For default setting Gain 3x, 18-bits, 100ms integration time, detectable lux 0.15 to 39K lux

OPTICAL SENSOR LTR-X100A

7.2 Device Operation (State Machine and Interrupt Features)

State Machine

Below diagram is the main state machine of LTR-X100A.

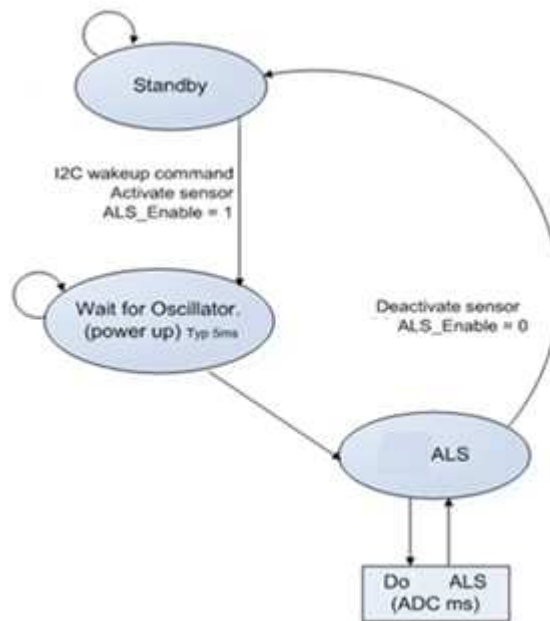

During the ALS Operation, ALS measurements can be activated by setting the ALS_Enable bit to 1. As soon as the ALS sensors become activated through an I2C command, the internal support blocks are powered on. Once the voltages and currents are settled (typically after 5ms), the state machine checks for trigger events from a measurement scheduler to start ALS conversions according to the selected measurement repeat rates. Once ALS_Enable is changed back to 0, a running conversion on the respective channel will be completed and the relevant ADCs and support blocks will move to power-down state.

OPTICAL SENSOR LTR-X100A

Interrupt Features

This device generates independent ALS interrupt signal that can be multiplexed and output to the INT output pin. The interrupt conditions are always evaluated after completion of a new conversion of the ALS channels. ALS interrupts is active low at the INT pin.

ALS Interrupt

The ALS interrupt is enabled by Bit 2 (ALS INT Pin Enabled) of INT_CFG register (0x19). The source is selected by Bit 4 and 5 (ALS INT Select) of INT_CFG register.

The INT is set when the data of the selected interrupt source is above the upper or below the lower threshold for a specified number of consecutive measurements set in ALS Persist in INT_PST register (0x1A).

The Interrupt signal is also stored in MAIN_STATUS register (0x07) as flag bit in Bit 4 (ALS INT Status). This status flag bit is cleared by reading the MAIN_STATUS register. A cleared flag will also clear the interrupt signal on the INT pin.

OPTICAL SENSOR LTR-X100A

8. Pseudo Codes Examples

Slave address

Slave_Addr = 0xA6

MAIN_CTRL Register

// This defines the operating modes of the ALS
// Default settings is 0x00 (ALS standby)

Register_Addr = 0x00
Command = 0x02

// MAIN_CTRL register
// ALS in Active Mode
// Command = 0x02, ALS in Active Mode,

WriteByte(Slave_Addr, Register_Addr, Command);

ALS_MEAS_RATE Register

// This controls the ALS measurement resolution and measurement rate.
// Default setting of the register is 0x22 (Resolution = 18 Bit, Measurement rate of 100ms)

Register_Addr = 0x04
Command = 0x41

// ALS_MEAS_RATE register
// Resolution = 16 bit, Meas Rate =50ms
// Command =0x25,Resolution = 18 bit, Meas Rate =1000ms
// Command =0x02, Resolution = 20 bit, Meas Rate =100ms

WriteByte(Slave_Addr, Register_Addr, Command)

ALS_GAIN Register

// This controls the ALS Gain Range.
// Default setting of the register is 0x01 (Gain Range = 3)

Register_Addr = 0x05
Command = 0x00

// ALS_GAIN register
// Gain = 1
// Command =0x04, Gain = 18

WriteByte(Slave_Addr, Register_Addr, Command)

MAIN_STATUS Register (Read Only)

// This Register contains the information on Interrupt, ALS data status.

Register_Addr = 0x07

// MAIN_STATUS register address

Data = ReadByte(Slave_Addr, Register_Addr)

Power_ON_Status = Data & 0x20

// If 0x20 Part went through power-up event
// If 0x00 Normal

ALS_Interrupt_Status = Data & 0x10

// If 0x10 Interrupt triggered

ALS_Data_Status = Data & 0x08

// If 0x00 Interrupt condition not fulfilled
// If 0x08 ALS data is new

CLEAR_DATA and ALS_DATA Registers (Read Only)

// The register 0x0A contains CLEAR_ADC 0 lower byte data.
// The register 0x0B contains CLEAR_ADC 1 upper byte data.
// The register 0x0C contains CLEAR_ADC 2 (top) upper byte data.
// The register 0x0D contains ALS_ADC 0 lower byte data.
// The register 0x0E contains ALS_ADC 1 upper byte data.
// The register 0x0F contains ALS_ADC 2 (top) upper byte data.

// These registers should be read as a group with block read function.

OPTICAL SENSOR LTR-X100A

```

Register_Addr = 0x0A // Started with Register CLEAR_DATA_0
Bytes_Count = 6 // Read 3 bytes for each CLEAR_DATA and ALS_DATA
DataArray=BlockReadByte(Slave_Addr, Register_Addr, Bytes_Count)
DataArray [0] = CLEAR_DATA_0
DataArray [1] = CLEAR_DATA_1
DataArray [2] = CLEAR_DATA_2
DataArray [3] = ALS_DATA_0
DataArray [4] = ALS_DATA_1
DataArray [5] = ALS_DATA_2

```

```

CLEAR_DATA = (CLEAR_DATA_2*256*256) + (CLEAR_DATA_1*256) + CLEAR_DATA_0
ALS_DATA = (ALS_DATA_2*256*256) + (ALS_DATA_1*256) + ALS_DATA_0
// Combine each 3 arrays to get CLEAR_DATA and ALS_DATA

```

INT_CFG Register

//This register controls the operation of the interrupt pins and options to trigger interrupt for ALS.
//The default value for this INT_CFG register is 0x10 (Interrupts inactive for both ALS)

```

Register_Addr = 0x19 // INT_CFG Register address
Command = 0x14 // Interrupt CH = ALS, ALS Interrupt Enable, Normal Trigger Mode

```

```
WriteByte(Slave_Addr, Register_Addr, Command)
```

INTERRUPT_PERSIST Register

// This register sets the ALS persist level.
// The default setting is 0x00. Interrupt at every ALS reading outside set thresholds.

```

Register_Addr = 0x1A // INT_PST register
Command = 0x00 // Interrupt for every ALS value outside threshold
// Command =0x10, Subsequent 2 ALS outside threshold range

```

```
WriteByte(Slave_Addr, Register_Addr, Command)
```

ALS_THRES Registers

//The register 0x21 contains ALS Interrupt upper threshold lower byte data (ALS_THRES_UP_0)
//The register 0x22 contains ALS Interrupt upper threshold 1 upper byte data (ALS_THRES_UP_1)
//The register 0x23 contains ALS Interrupt upper threshold 2 upper byte data (ALS_THRES_UP_2)

//The register 0x24 contains ALS Interrupt lower threshold lower byte data (ALS_THRES_LOW_0)
//The register 0x25 contains ALS Interrupt lower threshold 1 upper byte data (ALS_THRES_LOW_1)
//The register 0x26 contains ALS Interrupt lower threshold 2 upper byte data (ALS_THRES_LOW_2)

```

// To set ALS Upper threshold for Interrupt
Upper_Threshold_Value=1000 // Example 1000
Data2 = Upper_Threshold_Value >> 16 // Shift right to extract the 2 upper byte
Data1 = Upper_Threshold_Value >> 8 // Shift right to extract the 1 upper byte
Data0 = Upper_Threshold_Value & 0xFF // Mask to extract lower byte.

```

```

Register_Addr = 0x21 // ALS_THRES_UP_0 Register address
WriteByte(Slave_Addr, Register_Addr, Data0)
Register_Addr = 0x22 // ALS_THRES_UP_1 Register address
WriteByte(Slave_Addr, Register_Addr, Data1)
Register_Addr = 0x23 // ALS_THRES_UP_2 Register address
WriteByte(Slave_Addr, Register_Addr, Data2)

```

```

// To set ALS Lower threshold for Interrupt
Lower_Threshold_Value=100 // Example 100
Data2 = Lower_Threshold_Value >> 16 // Shift right to extract the 2 upper byte

```

OPTICAL SENSOR LTR-X100A

```
Data1 = Lower_Threshold_Value >> 8  
Data0 = Lower_Threshold_Value & 0xFF
```

```
Register_Addr = 0x24  
WriteByte(Slave_Addr, Register_Addr, Data0)  
Register_Addr = 0x25  
WriteByte(Slave_Addr, Register_Addr, Data1)  
Register_Addr = 0x26  
WriteByte(Slave_Addr, Register_Addr, Data2)
```

```
// Shift right to extract the 1 upper byte  
// Mask to extract lower byte.
```

```
// ALS_THRES_LOW_0 Register address
```

```
// ALS_THRES_LOW_1 Register address
```

```
// ALS_THRES_LOW_2 Register address
```

OPTICAL SENSOR LTR-X100A

9. Recommended Lead-free Reflow Profile

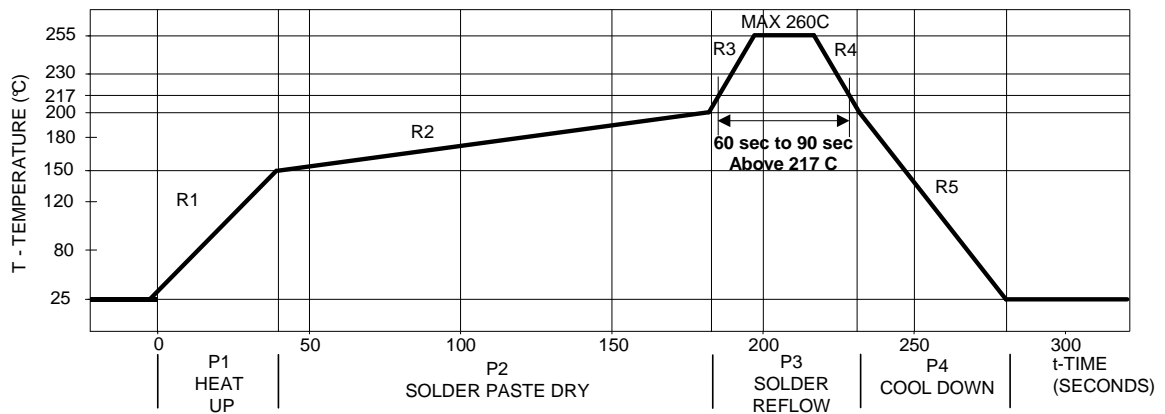

Process Zone	Symbol	ΔT	Maximum $\Delta T/\Delta$ time or Duration
Heat Up	P1, R1	25°C to 150°C	3°C/s
Solder Paste Dry	P2, R2	150°C to 200°C	100s to 180s
Solder Reflow	P3, R3	200°C to 260°C	3°C/s
	P3, R4	260°C to 200°C	-6°C/s
Cool Down	P4, R5	200°C to 25°C	-6°C/s
Time maintained above liquid's point, 217°C		> 217°C	60s to 90s
Peak Temperature		260°C	-
Time within 5°C of actual Peak Temperature		> 255°C	20s
Time 25°C to Peak Temperature		25°C to 260°C	8mins

It is recommended to perform reflow soldering no more than twice.

OPTICAL SENSOR LTR-X100A

10. Moisture Proof Packaging

All LTR-X100A are shipped in moisture proof package. Once opened, moisture absorption begins. This part is compliant to JEDEC J-STD-033A Level 3.

Time from Unsealing to Soldering

After removal from the moisture barrier bag, the parts should be stored at the recommended storage conditions and soldered within seven days. When the moisture barrier bag is opened and the parts are exposed to the recommended storage conditions for more than seven days, the parts must be baked before reflow to prevent damage to the parts.

Recommended Storage Conditions

Storage Temperature	10°C to 30°C
Relative Humidity	Below 60% RH

Baking Conditions

Package	Temperature	Time
In Reels	60°C	48 hours
In Bulk	100°C	4 hours

Baking should only be done once.

OPTICAL SENSOR LTR-X100A

10. Recommended Land Pattern

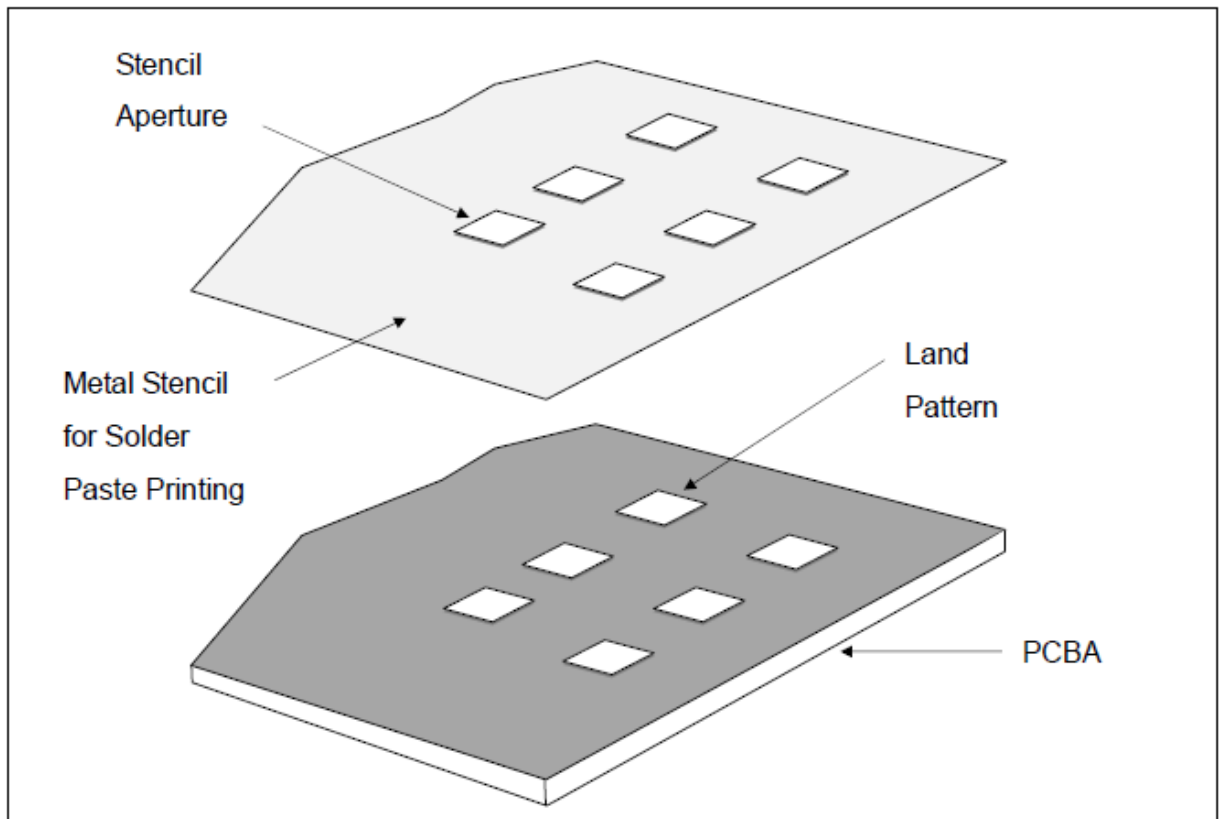

Recommended Land Pattern for LTR-X100A

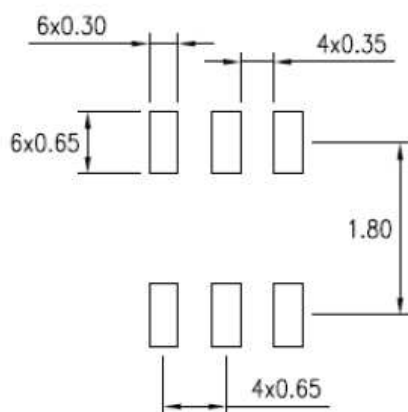

Note: All dimensions are in millimeters

OPTICAL SENSOR LTR-X100A

11. Metal Stencil Aperture

It is recommended that the metal stencil used for solder paste printing has a thickness (t) of 0.11mm (0.004 inches / 4 mils) or 0.127mm (0.005 inches / 5 mils).

The stencil aperture opening is recommended to be 0.3mm x 0.65mm which has the same dimension as the land pattern. This is to ensure adequate printed solder paste volume and yet no shorting.

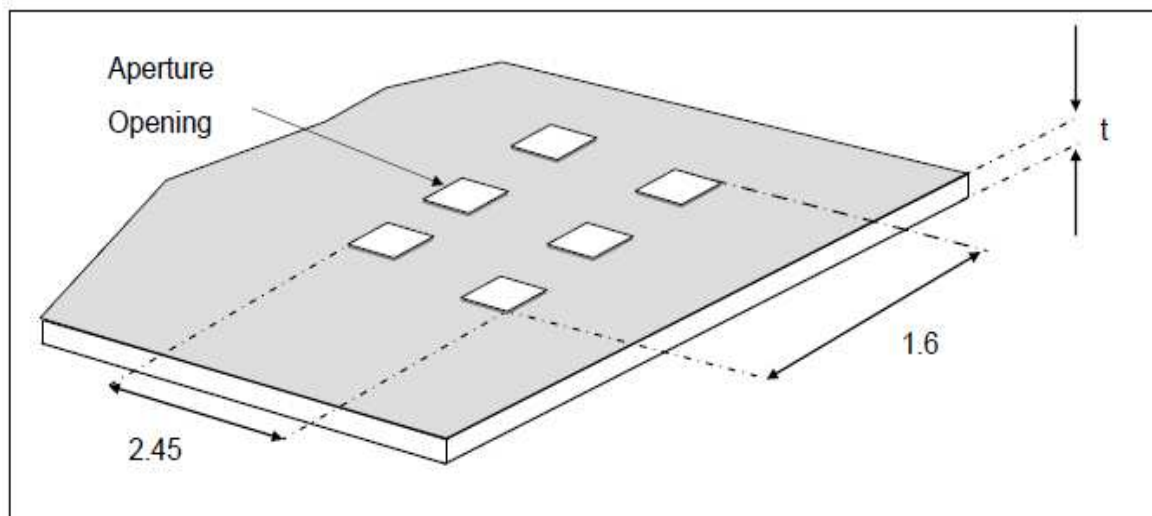

Note:

1. All dimensions are in millimeters

OPTICAL SENSOR LTR-X100A

12. Tape and Reel Dimensions

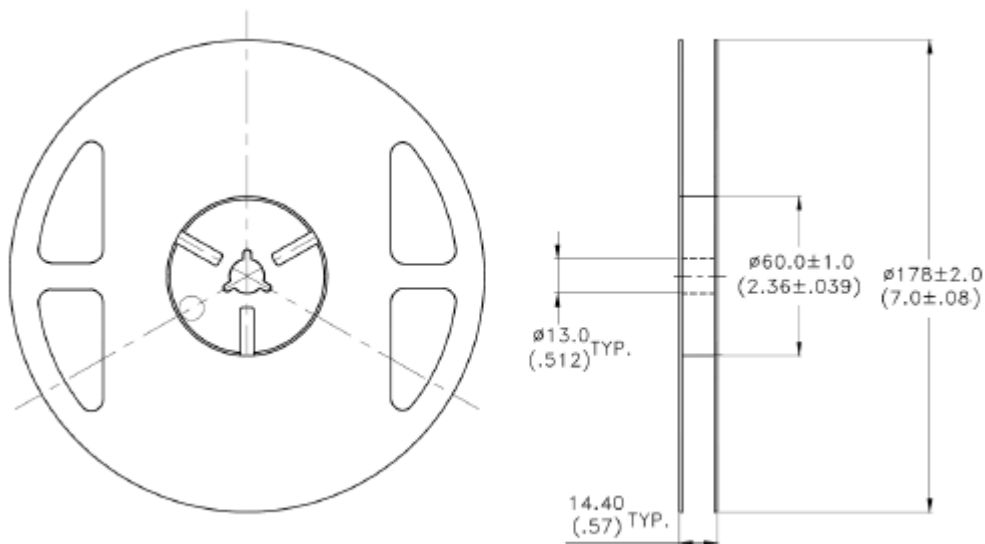
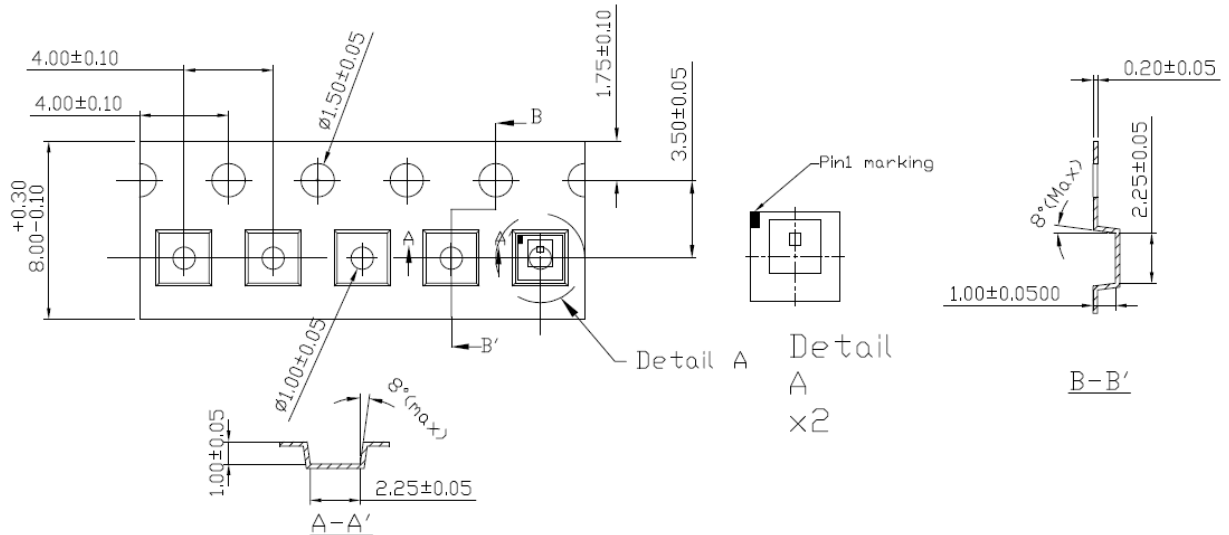

Notes:

1. All dimensions are in millimeters (inches)
2. Empty component pockets sealed with top cover tape
3. 7 inch reel - 2500 pieces per reel
4. In accordance with ANSI/EIA 481-1-A-1994 specifications

**OPTICAL SENSOR
LTR-X100A**

Revision Table:

Version	Update	Page	Date
1.0	Final Datasheet as created	Total 31	24-Jun-20