



**Optical Sensor**  
**Product Data Sheet**  
LTR-X221A

Spec No. :DS86-2022-0014  
Effective Date: 09/14/2024  
Revision: A

**LITE-ON DCC**

**RELEASE**

**BNS-OD-FC001/A4**

## OPTICAL SENSOR LTR-X221A

### Descriptions

The LTR-X221A is a low power digital ambient light sensor (ALS) that measures the intensity of ambient light. The spectral response of the ALS approximates human eye response and features enhanced IR rejection capability. The LTR-X221A also incorporates an IR channel with peak response at 850nm and can function as 850nm IR metering.

The LTR-X221A's ultra-sensitive ALS photodiode enables high accuracy metering with short integration time under low lux environment, which allows the use of high transmission attenuation cover material for aesthetics industrial designs. In addition, the operating range can be easily extended to over 35K lux when low gain mode is used.

The digital operation modes are flexible for system integration. Measurements can be performed with either single or continuous mode. The highly configurable interrupt system enables the sensor to trigger the host system to read out the data through 2-wire serial interface only when the pre-defined conditions are met, hence allowing the host system to sleep or reducing the host system's load.

The LTR-X221A features wide operating range compatible with both 1.8V and 3V systems. The low power consumption helps to enhance the battery life and is well suited for battery-operated systems.

### Applications

- Ambient Light and IR Light Sensing
- IP Cameras, Doorbell Cameras Day/Night Mode IR Illuminations Control System
- Display Backlight Control for Table, Notebook, Point-of-Sales Terminal
- Lighting, Home Automation Control Systems

### Features

- Ambient light sensing with excellent IR rejection
- Measurement range: 0.001 lux to 35K lux
- High Accuracy in low ambient brightness environment
- High sensitivity, suited for operation behind dark/low transmission cover
- I2C interface (Standard mode @100kHz or Fast mode @400kHz)
- Up to 16 bits effective resolution
- High gain setting up to 1024 times
- Built-in automatic gain switching feature
- Short/Programmable integration time
- Low power consumption suitable for battery operated devices
- Operating voltage ranges: 1.7V to 3.3V
- Operating temperature ranges: -40 to +85 °C
- Package: LGA 2.0 mm x 2.0 mm x 0.70 mm
- RoHS and Halogen free compliant

## OPTICAL SENSOR LTR-X221A

### Device Information

Part Number	Packaging Type	Package	Quantity
LTR-X221A	Tape and Reel	6-pin chipled package	3500

Table 1

### 1. Outline Dimensions and Pins Configuration

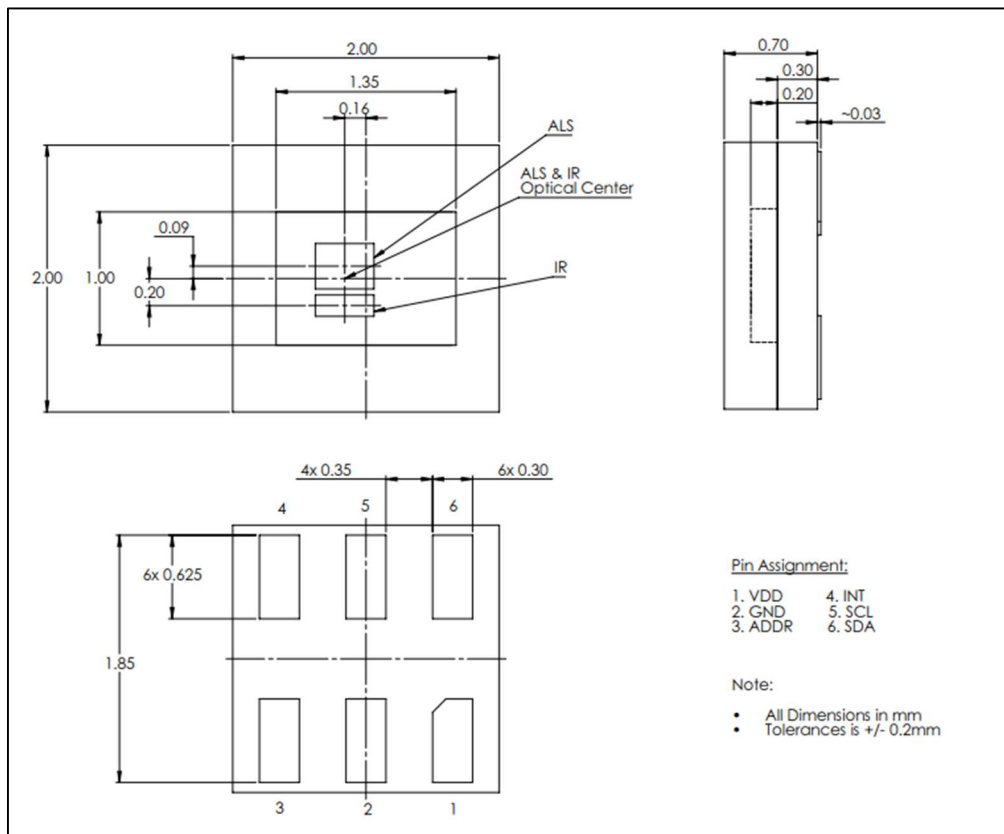

Figure 1 Outline Dimensions and Pins Assignment

## OPTICAL SENSOR LTR-X221A

Pin	I/O Type	Symbol	Description
1	Supply	VDD	Power Supply Voltage
2	GND	GND	Ground
3	I	ADDR	Address pin
4	I/O	GPIO/INT	General Purpose Input/Output, Interrupt Pin
5	I	SCL	I <sup>2</sup> C serial clock
6	I/O	SDA	I <sup>2</sup> C serial data

*Table 2 I/O Pins Configuration Table*

**OPTICAL SENSOR  
LTR-X221A**

**2. Functional Block Diagram**

The LTR-X221A contains a photodiode for ALS measurement. The photodiode currents are converted to digital values by ADCs. The sensor also includes some peripheral circuits such as an internal oscillator, a current source, voltage reference, and internal fuses to store trimming information.

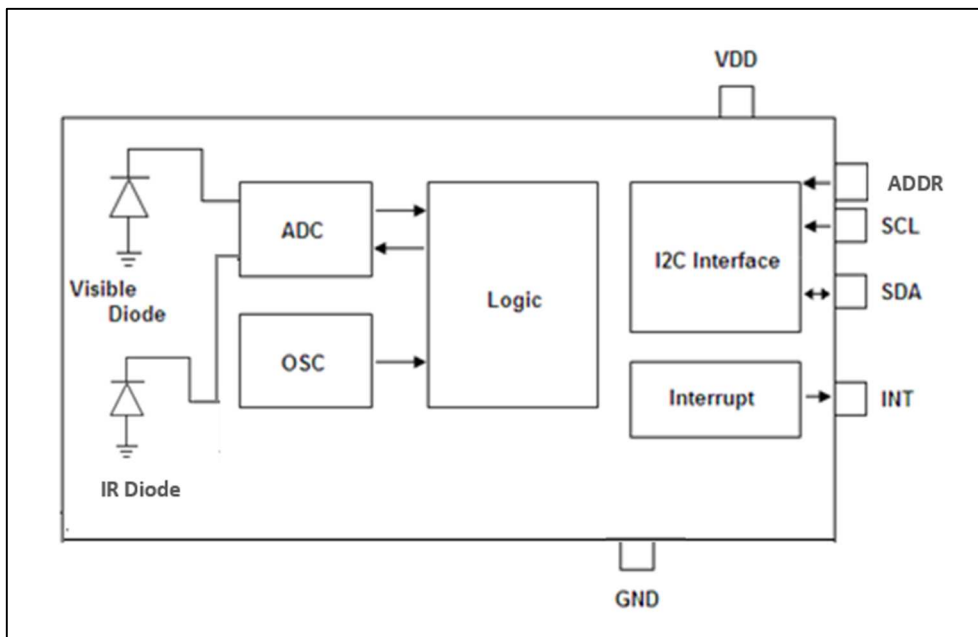

Figure 2 Functional Block Diagram

### 3. Application Circuit

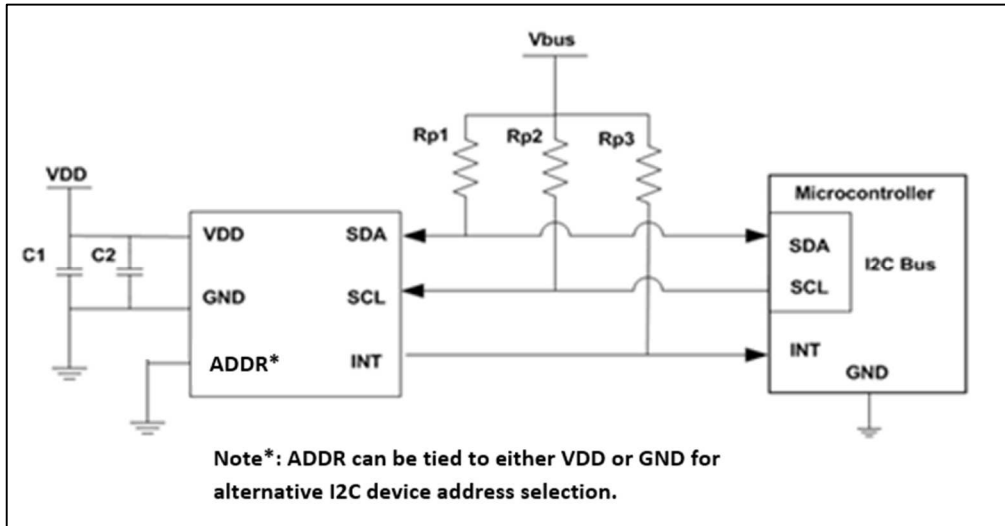

Figure 3 Application Circuit

Component	Recommended Value
Rp1, Rp2, Rp3 <sup>(1)</sup>	1 kΩ to 10 kΩ
C1	0.1uF
C2	1.0uF

Table 3 Application Circuit Components Recommendation

(1) Selection of pull-up resistors value is dependent on bus capacitance values. For more details, please refer to I2C Specifications:  
[http://www.nxp.com/documents/user\\_manual/UM10204.pdf](http://www.nxp.com/documents/user_manual/UM10204.pdf)

## OPTICAL SENSOR LTR-X221A

### 4. Ratings and Specifications

#### Absolute Maximum Ratings

Parameter	Symbol	Minimum	Maximum	Unit
Supply Voltage	VDD		3.6	V
Digital Voltage Range	SCL, SDA, INT	-0.5	3.6	V
Storage Temperature	T <sub>STG</sub>	-40	100	°C
Electrostatic Discharge Protection (Human Body Model JESD22-A114)	V <sub>HBM</sub>	+/-2000		V
Electrostatic Discharge Protection (Charged Device Model JESD22-C101)	V <sub>CDM</sub>	+/-1000		V
Junction Temperature Range	T <sub>J</sub>	-40	175	°C

Table 4 Absolute Maximum Ratings

Note: Exceeding these ratings could cause damage to the sensor. All voltages are with respect to ground. Exposure to temperatures higher than 100°C for long times can cause package discoloration, spectral distortion, and measurement inaccuracy. Currents are positive into, negative out of the specified terminal.

#### Recommended Operating Conditions

Parameter	Symbol	Minimum	Typical	Maximum	Unit
Supply Voltage	VDD	1.7		3.3	V
Interface signal input high	V <sub>I2Chigh</sub>	1.5		VDD	V
Interface signal input low	V <sub>I2Clow</sub>	0		0.4	V
Operating Temperature	T <sub>OPE</sub>	-40		85	°C

Table 5 Recommended Operating Conditions

#### Thermal Information

Parameter	Symbol	Typical	Unit
Junction-to-ambient thermal resistance	R <sub>JA</sub>	180	K/W
Junction-to-board thermal resistance	R <sub>JB</sub>	145	K/W

Table 6 Thermal Information

## OPTICAL SENSOR LTR-X221A

### Electrical Characteristics

All specifications are at VDD = 3.0V, T<sub>OPe</sub> = 25°C, unless otherwise specified.

Parameter	Minimum	Typical <sup>(7)</sup>	Maximum	Unit	Condition
Active Supply Current <sup>(1)</sup>		52		uA	Continuous active mode, Wait Time Steps = 0.
Active Idle Supply Current <sup>(6)</sup>		3.9		uA	During active idle period set by Wait Time.
Standby Current		0.35		uA	Shutdown Mode, no I2C activities.
Resolution <sup>(2)</sup>			16	Bit	Automatically managed by sensor.
Gain <sup>(2)</sup>	1		1024	Times	Programmable to 1, 2, 4, ..., 1024x.
Integration Time <sup>(3)</sup>	10		800	ms	Programmable.
Dark Output		0		Count	Integration time 100ms, Gain 512x.
Sensitivity – ALS Channel <sup>(4)</sup>		0.0042		Lux / Count	Integration time 100ms, Gain 128x.
Sensitivity – IR Channel <sup>(5)</sup>		0.0003		uW/cm <sup>2</sup> / Count	Integration time 100ms, Gain 128x.
Output Count – ALS Channel <sup>(4)</sup>	-15		+15	%	Integration time 100ms, Gain 128x, 100 lux.
Output Count – IR Channel <sup>(5)</sup>	-15		+15	%	Integration time 100ms, Gain 128x, 8uW/cm <sup>2</sup> .
Saturation Level – ALS Channel <sup>(6)</sup>		35000		Lux	Integration time 100ms, Gain 1x.
Saturation Level – IR Channel <sup>(6)</sup>		20000		uW/cm <sup>2</sup>	Integration time 100ms, Gain 1x, IR Gain Select 1/8x.
Wait Time <sup>(3)</sup>	0.2		400	ms	Programmable, active idle period before repeating next photodiode integrating period.
Wakeup Time from Standby <sup>(3)</sup>			5	ms	From Standby to Active mode where measurement can start.
Internal Clock Accuracy	-15		+15	%	For additional variation across VDD and temperature, see characteristics charts.

Table 7 Electrical Characteristics

#### Notes:

- (1) Active current is average current measured with Wait Time Steps set at 0. Effective duty cycle is approximately 100%.
- (2) Parameter ensured by design and is not tested.
- (3) Parameter is not tested in production. Accuracy is governed by Internal Clock accuracy.
- (4) Optical tests are performed at component level, using white LED (approximately 5000K CCT) source at small incident angle compatible with high volume production automated test equipment.
- (5) Optical tests are performed at component level, using 850nm IR LED source at small incident angle compatible with high volume production automated test equipment.
- (6) Parameter represents characterized performance and is not tested in production.
- (7) Due to conditions of the manufacturing processes, the typical data can only reflect statistical figures. Where technical improvements are required, these typical data will be changed without any further notice.



## OPTICAL SENSOR LTR-X221A

### Typical Characteristics

All characteristics are at  $V_{DD} = 3.0V$ ,  $T_{OPE} = 25^{\circ}C$ , default power up settings, unless otherwise specified.

(Note that mandatory settings listed in the **Power Up Configurations** in Section 6 should be applied where relevant)

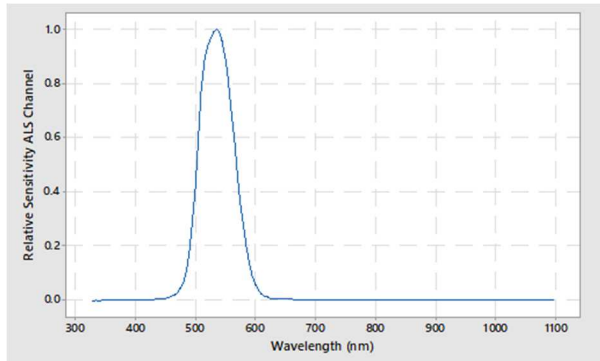

Figure 4 Relative Sensitivity of ALS Channel

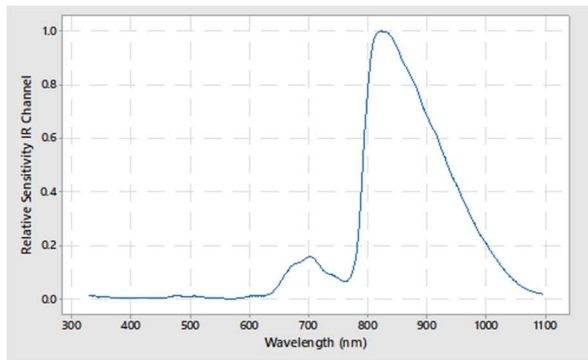

Figure 5 Relative Sensitivity of IR Channel

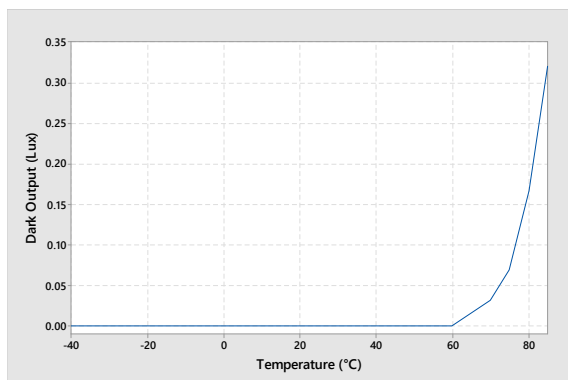

Figure 6 ALS Channel Dark Response vs Temperature

## OPTICAL SENSOR LTR-X221A

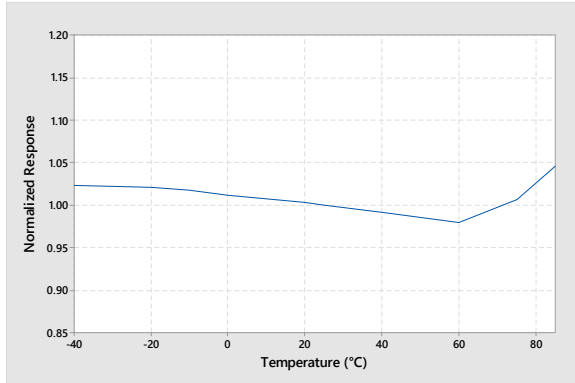

Figure 7 ALS Channel Normalized Response vs Temperature

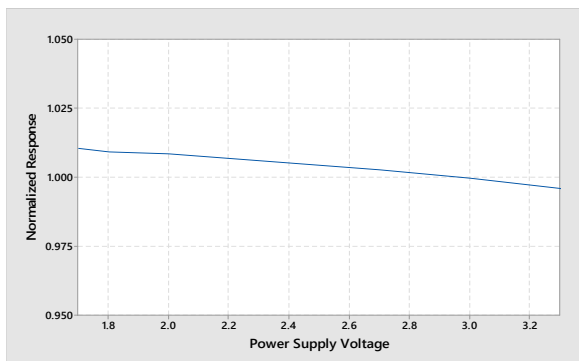

Figure 8 ALS Channel Normalized Response vs VDD

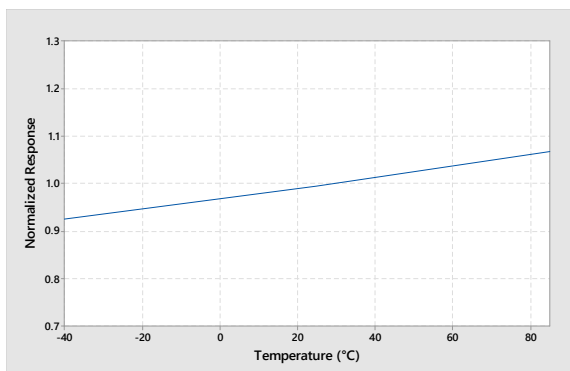

Figure 9 Normalized Internal Clock Frequency vs Temperature

**OPTICAL SENSOR  
LTR-X221A**

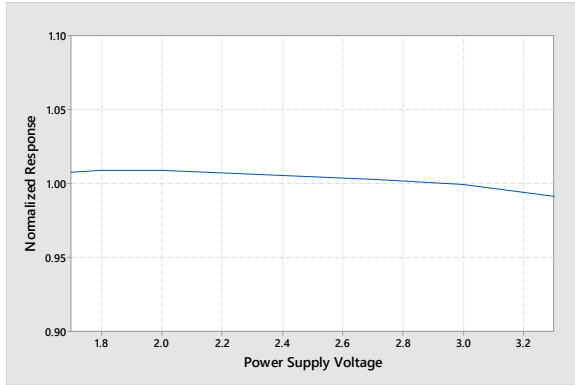

Figure 10 Normalized Internal Clock Frequency vs VDD

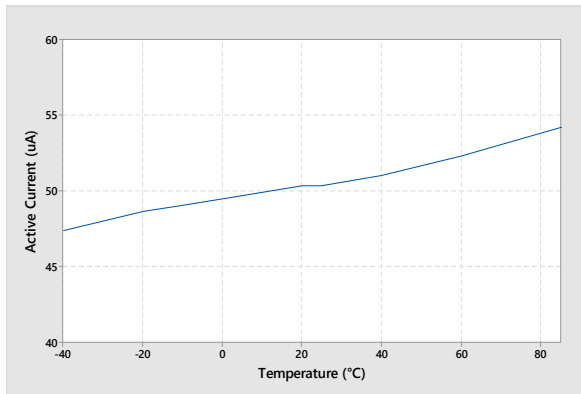

Figure 11 Active Current vs Temperature (Continuous Mode)

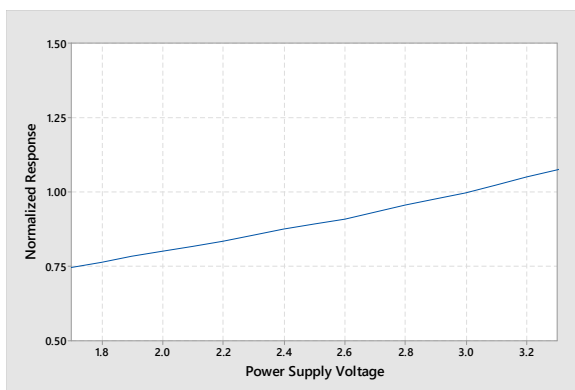

Figure 12 Active Current vs VDD (Continuous Mode)

**OPTICAL SENSOR  
LTR-X221A**

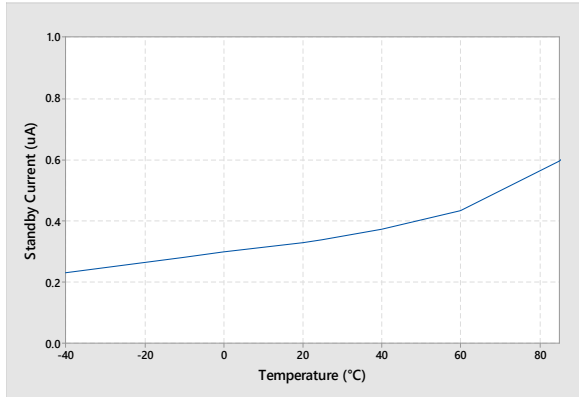

Figure 13 Standby Current vs Temperature

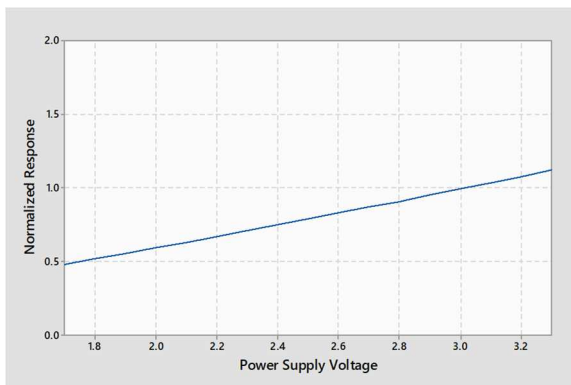

Figure 14 Standby Current vs VDD

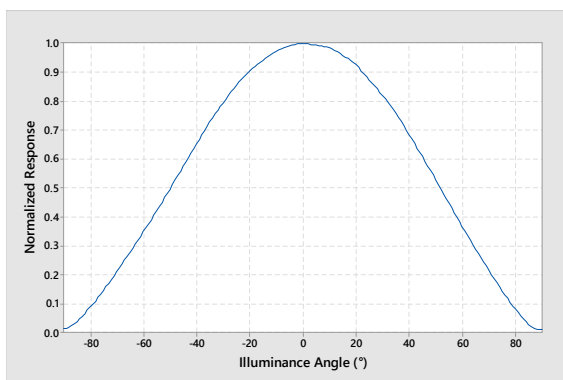

Figure 15 ALS Channel Normalized Response vs Illuminance Angle

### 5. Timing Requirements

#### Electrical Characteristics

All specifications are at V<sub>BUS</sub> = 3.0V, T<sub>OP</sub>E = 25°C, unless otherwise specified.

Parameter	Symbol	Standard mode		Fast mode		Unit
		Min.	Max.	Min.	Max.	
SCL clock frequency	$f_{SCL}$	100		400		kHz
Bus free time between a STOP and START condition	$t_{BUF}$	4.7	-	1.3	-	us
Hold time (repeated) START condition. After this period, the first clock pulse is generated	$t_{HD,STA}$	4.0	-	0.6	-	us
LOW period of the SCL clock	$t_{LOW}$	4.7	-	1.3	-	us
HIGH period of the SCL clock	$t_{HIGH}$	4.0	-	0.6	-	us
Set-up time for a repeated START condition	$t_{SU,STA}$	4.7	-	0.6	-	us
Set-up time for STOP condition	$t_{SU,STO}$	4.0	-	0.6	-	us
Rise time of both SDA and SCL signals	$t_r$	-	1000	-	300	ns
Fall time of both SDA and SCL signals	$t_f$	-	300	-	300	ns
Data hold time	$t_{HD,DAT}$	0	-	0	-	us
Data setup time	$t_{SU,DAT}$	250	-	100	-	ns

Table 8 Communication Timing Requirements

## OPTICAL SENSOR LTR-X221A

### I<sup>2</sup>C Protocols

I<sup>2</sup>C Write Protocol (type 1):

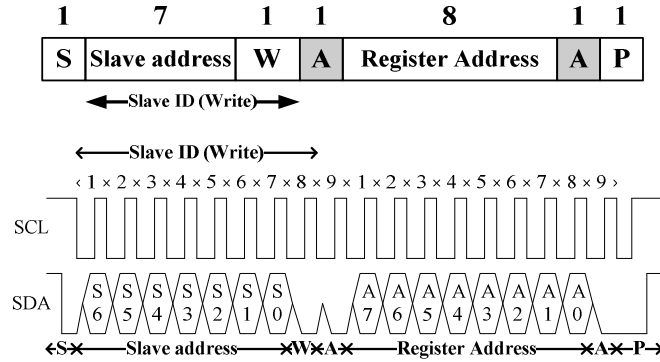

Figure 16

I<sup>2</sup>C Write Protocol (type 2):

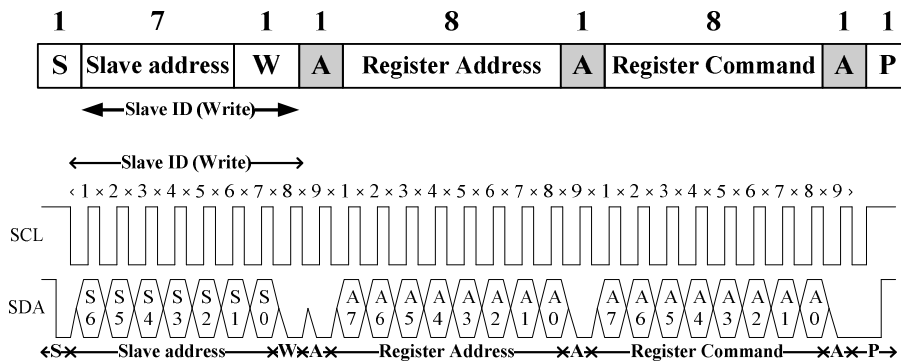

Figure 17

## OPTICAL SENSOR LTR-X221A

I<sup>2</sup>C Read Protocol:

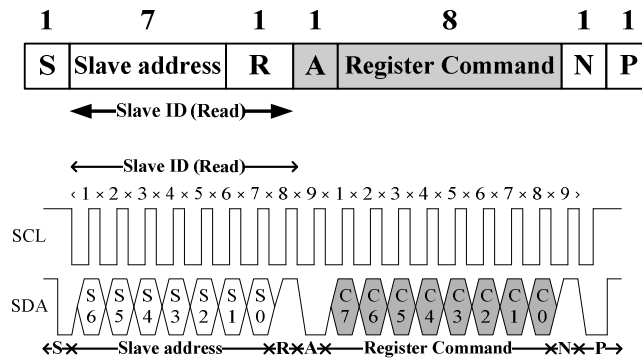

Figure 18

I<sup>2</sup>C Read (Combined format) Protocol:

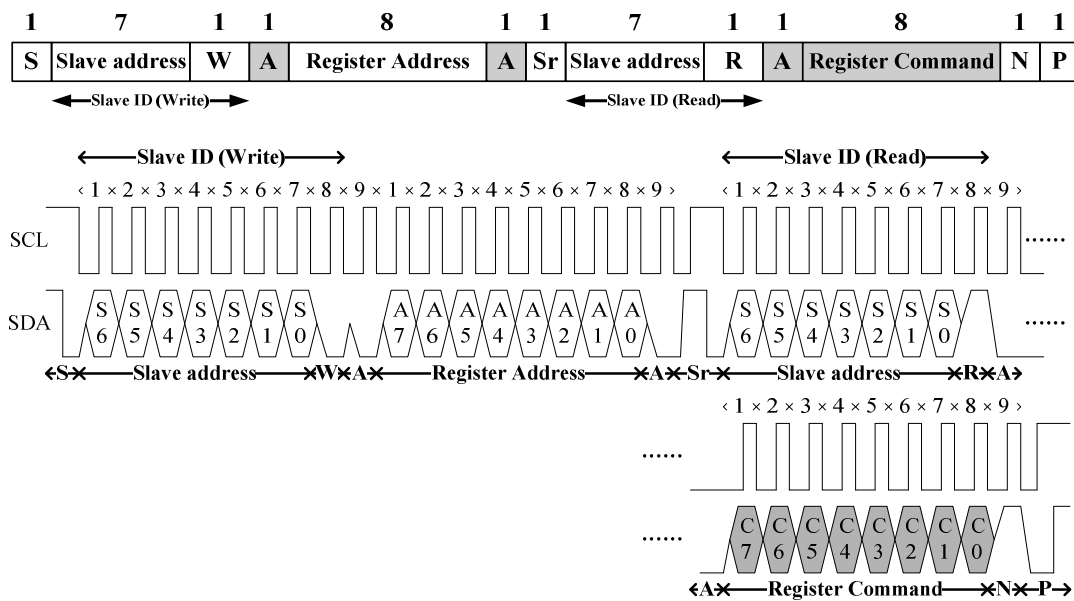

Figure 19

- |                                     |                            |                          |                                |
|-------------------------------------|----------------------------|--------------------------|--------------------------------|
| <b>A</b>                            | Acknowledge (0 for an ACK) | <b>N</b>                 | Non-Acknowledge (1 for a NACK) |
| <b>S</b>                            | Start condition            | <b>Sr</b>                | Repeated Start condition       |
| <b>P</b>                            | Stop condition             | <b>R</b>                 | Read (1 for read)              |
| <b>W</b>                            | Write (0 for writing)      | <input type="checkbox"/> | Master-to-Slave                |
| <input checked="" type="checkbox"/> | Slave-to-master            |                          |                                |

## OPTICAL SENSOR LTR-X221A

### Device Slave Address

The 7 bits slave address of this sensor is depends on address pin configuration as referred to table below.

ADDR PIN	7-bit Slave Address
GND	0x23H
VDD	0x22H

*Table 9 Device Slave Address*



## OPTICAL SENSOR LTR-X221A

### 6. Registers Set

Address	R / W	Register Name	Description	Reset Value
0x80	RW	ALS_CONTROL	ALS operation mode control	0x64
0x81	RW	ALS_TIME_SCALE	ALS integration time and measurement rate time scale	0x03
0x82	RW	ALS_INT_TIME_STEP	ALS integration time steps	0x3F
0x83	RW	ALS_WAIT_TIME_STEP	ALS measurement wait time steps	0x7F
0x84	R	ALS_STATUS	ALS Status	0x00
0x86	R	DARK_DATA_LSB	DARK channel measurement data, LSB	0x00
0x87	R	DARK_DATA_MSB	DARK channel measurement data, MSB	0x00
0x88	R	ALS_DATA_LSB	ALS channel measurement data, LSB	0x00
0x89	R	ALS_DATA_MSB	ALS channel measurement data, MSB	0x00
0x8A	R	IR_DATA_LSB	IR channel measurement data, LSB	0x00
0x8B	R	IR_DATA_MSB	IR channel measurement data, MSB	0x00
0x8D	RW	ALS_CONFIG2	Configuration 2	0x40
0x8E	RW	ALS_CONFIG3	Configuration 3	0x40
0x8F	RW	IR_ENABLE	Enable IR Channel	0x40
0x90	RW	ALS_AGC_CONTROL	ALS automatic gain control	0x0C
0x91	RW	ALS_THRES_UPPER_LSB	ALS interrupt upper threshold, LSB	0xFF
0x92	RW	ALS_THRES_UPPER_MSB	ALS interrupt upper threshold, MSB	0xFF
0x93	RW	ALS_THRES_LOWER_LSB	ALS interrupt lower threshold, LSB	0x00
0x94	RW	ALS_THRES_LOWER_MSB	ALS interrupt lower threshold, MSB	0x00
0x95	RW	ALS_CONFIG1	Configuration 1	0x47
0x98	RW	ALS_CONTROL2	Software reset, IR Gain divider, Single Mode control	0x44
0x99	RW	INTERRUPT	Interrupt settings	0x00
0x9A	R	INTERRUPT_STATUS	Interrupt status	0x00
0x9B	RW	INTERRUPT_PERSIST	Interrupt persist setting	0x00
0x9D	R	PART_ID	Part ID	0xB0
0x9E	R	MANUFAC_ID	Manufacture ID	0x05
0xC9	RW	ALS_CONFIG4	Configuration 4	0x06
0xCA	RW	ALS_CONFIG5	Configuration 5	0x06

Table 10 Registers Set

### Power Up Configurations

The following is an example of power up configurations to setup the sensor for operation: Gain 512x, Integration time ~100ms, and short wait time. **Take note of the mandatory registers to setup, regardless of other settings.**

Write 0x98 0x05 ; Soft reset sensor by writing 1 to bit[0].  
Write 0x80 0x64 ; Always disable ALS operation before changing settings  
Write 0x81 0x07 ; Set ALS\_INT\_TIME\_SCALE to 1.56ms  
Write 0x82 0x3F ; Set integration time to 99.84ms (1.56ms x 64 steps)  
Write 0x83 0x00 ; Set wait time to 1.56ms (1.56ms x 1 step)  
**Write 0x8D 0x48 ; Mandatory to write 100\_1000 to bit[6:0]**  
**Write 0x8E 0x44 ; Mandatory to write 100\_0100 to bit[6:0]**  
Write 0x8F 0x40 ; Enable IR channel  
**Write 0x98 0x04 ; Mandatory to write 0 to bit[6]**  
**Write 0xC9 0x3E ; Mandatory to write 1111 to bit[5:2]**  
**Write 0xCA 0x0E ; Mandatory to write 11 to bit[3:2]**  
Write 0x80 0x65 ; Set Gain 512x, enable ALS in continuous mode

## OPTICAL SENSOR LTR-X221A

### ALS\_CONTROL Register (0x80) (Read/Write)

The ALS\_CONTROL register controls the ALS operation modes for the sensor. The ALS sensor can be set to either standby mode, active continuous mode or single mode. At either of these modes, the I2C circuitry is always active. The default mode after power up is standby mode. If single mode is set, the sensor will enter active idle mode waiting for measurement trigger. To run ALS measurement once, refer to ALS\_CONTROL2 register for details.

**Note that to ensure proper operation, the ALS mode must be set to standby mode first before any change is made to the sensor's registers settings.**

0x80	ALS_CONTROL (default = 0x64)							
	Bit 7	Bit 6	Bit 5	Bit 4	Bit 3	Bit 2	Bit 1	Bit 0
	Reserved		ALS Gain				ALS Mode	

Field	Bits	Default	Description	
Reserved	7:6	01	Must write 01.	
ALS Gain	5:2	1001	0000	Gain 1X
			0001	Gain 2X
			0010	Gain 4X
			0011	Gain 8X
			0100	Gain 16X
			0101	Gain 32X
			0110	Gain 64X
			0111	Gain 128X
			1000	Gain 256X
			1001	Gain 512X ( <b>default</b> )
			1010	Gain 1024X
	1011~1111		Reserved	
ALS Mode	1:0	00	00	Standby mode ( <b>default</b> )
			01	Active continuous mode
			10	Single mode
			11	Reserved

## OPTICAL SENSOR LTR-X221A

### ALS\_TIME\_SCALE Register (0x81) (Read/Write)

The ALS\_TIME\_SCALE register controls the scale of integration time and timing of the periodic measurement of the ALS in active mode. Register 0x82 & 0x83 setting will be based on scale setting in register 0x81.

0x81	ALS_TIME_SCALE (default = 0x03)							
	Bit 7	Bit 6	Bit 5	Bit 4	Bit 3	Bit 2	Bit 1	Bit 0
	<i>Reserved</i>				<i>ALS Integration Time Scale</i>		<i>ALS Wait Time Scale</i>	

Field	Bits	Default	Description	
Reserved	7:4	0000	Must write 0000.	
ALS Integration Time Scale	3:2	00	00	3.12ms per steps <b>(default)</b>
			01	1.56ms per steps
			10	0.78ms per steps
			11	0.39ms per steps
ALS Wait Time Scale	1:0	11	00	0.2ms per steps
			01	0.39ms per steps
			10	0.78ms per steps
			11	1.56ms per steps <b>(default)</b>

## OPTICAL SENSOR LTR-X221A

### ALS\_INT\_TIME\_STEP Register (0x82) (Read/Write)

The ALS\_INT\_TIME\_STEP register controls the integration time of the ALS in active mode. For example, 100ms integration time = 3.12ms per steps \* 32 steps. Setting 0 in this register is equivalent to 1 step.

0x82	ALS_INT_TIME_STEP (default = 0x3F)							
	Bit 7	Bit 6	Bit 5	Bit 4	Bit 3	Bit 2	Bit 1	Bit 0
	<i>Integration Time Steps</i>							

Field	Bits	Default	Description
Integration Time Steps	7:0	00111111	Specifies ALS integration time number of steps. Refer 0x81 bit [3:2] for integration time scale per steps.

### ALS\_WAIT\_TIME\_STEP Register (0x83) (Read/Write)

The ALS\_WAIT\_TIME\_STEP register controls the Wait Time of the ALS in active mode after completing the previous integration period and before starting the next integration period. During this Wait Time period, ALS will stay in active-idle mode and consumes less power. For example, 100ms Wait Time = 1.56ms per steps \* 64 steps. Setting 0 in this register is equivalent to 1 step.

0x83	ALS_WAIT_TIME_STEP (default = 0x7F)							
	Bit 7	Bit 6	Bit 5	Bit 4	Bit 3	Bit 2	Bit 1	Bit 0
	<i>Wait Time Steps</i>							

Field	Bits	Default	Description
Wait Time Steps	7:0	01111111	Specifies ALS measurement rate number of steps. Refer 0x81 bit [1:0] for measurement rate scale per steps.

## OPTICAL SENSOR LTR-X221A

### ALS\_STATUS Register (0x84) (Read Only)

The ALS\_STATUS register stores information about ALS data status. New data means data has not been read before. Every time measurement is done, and data is written to the data register, ALS Data Status bit will be set to logic 1. To clear ALS Data Status bit to 0, the three registers pairs from address 0x86 to address 0x8B should be read in block.

ALS/IR Data Invalid indicates validity of the ALS or IR data. In the event of data saturation, this bit will be set. Note that if IR channel is enabled, saturation of IR channel will also set the ALS/IR Data Invalid bit, even if ALS channel is not saturated.

0x84	ALS_STATUS (default = 0x00)							
	Bit 7	Bit 6	Bit 5	Bit 4	Bit 3	Bit 2	Bit 1	Bit 0
	Reserved		ALS/IR Data Invalid	ALS Data Gain			ALS Data Status	

Field	Bits	Default	Description	
Reserved	7:6	00	Reserved	
ALS/IR Data Invalid	5	0	0	ALS/IR Data is Valid ( <b>default</b> )
			1	ALS/IR Data is Invalid
ALS Data Gain	4:1	0000	0000	Gain 1X ( <b>default</b> )
			0001	Gain 2X
			0010	Gain 4X
			0011	Gain 8X
			0100	Gain 16X
			0101	Gain 32X
			0110	Gain 64X
			0111	Gain 128X
			1000	Gain 256X
			1001	Gain 512X
			1010	Gain 1024X
1011~1111	Reserved			
ALS Data Status	0	0	0	OLD data (data already read) ( <b>default</b> )
			1	NEW data (first time data is read)

## OPTICAL SENSOR LTR-X221A

### DARK\_DATA Register (0x86,0x87) (Read Only)

DARK channel measurement results are stored in DARK\_DATA registers. Data from this register is used internally by the sensor, and not required for lux calculations. However, reading the three registers pairs from address 0x86 to address 0x8B is required to clear the ALS Data Status bit. Refer to register 0x84 for details.

Field	Bits	Default	Description
DARK_DATA_LSB	0x86	0	DARK low byte data, bit 0 is LSB of the 16-bit data
DARK_DATA_MSB	0x87	0	DARK high byte data, bit 7 is MSB of the 16-bit data

### ALS\_DATA Register (0x88,0x89) (Read Only)

ALS measurement results are stored in ALS\_DATA registers.

Field	Bits	Default	Description
ALS_DATA_LSB	0x88	0	ALS low byte data, bit 0 is LSB of the 16-bit data
ALS_DATA_MSB	0x89	0	ALS high byte data, bit 7 is MSB of the 16-bit data

### IR\_DATA Register (0x8A,0x8B) (Read Only)

IR measurement results are stored in IR\_DATA registers.

Field	Bits	Default	Description
IR_DATA_LSB	0x8A	0	IR low byte data, bit 0 is LSB of the 16-bit data
IR_DATA_MSB	0x8B	0	IR high byte data, bit 7 is MSB of the 16-bit data

## OPTICAL SENSOR LTR-X221A

### ALS\_CONFIG2 (0x8D) (Read/Write)

The ALS\_CONFIG2 register must be set as 0x48.

0x8D	ALS_CONFIG4 (default = 0x40)							
	Bit 7	Bit 6	Bit 5	Bit 4	Bit 3	Bit 2	Bit 1	Bit 0
	<i>Reserved</i>							

Field	Bits	Default	Description
Reserved	7:0	01000000	Must write 01001000

### ALS\_CONFIG3 (0x8E) (Read/Write)

The ALS\_CONFIG3 register must be set as 0x44.

0x8E	ALS_CONFIG5 (default = 0x40)							
	Bit 7	Bit 6	Bit 5	Bit 4	Bit 3	Bit 2	Bit 1	Bit 0
	<i>Reserved</i>							

Field	Bits	Default	Description
Reserved	7:0	01000000	Must write as 01000100



## OPTICAL SENSOR LTR-X221A

### IR\_ENABLE Register (0x8F) (Read/Write)

The IR\_ENABLE bit activates IR channel when set. The gain and integration time settings of IR channel will follow the settings of ALS channel. Additional divider scaling is available for IR channel gain. See ALS\_CONTROL2 register for details.

0x8F	IR_ENABLE (default = 0x40)							
	Bit 7	Bit 6	Bit 5	Bit 4	Bit 3	Bit 2	Bit 1	Bit 0
	<i>Reserved</i>	<i>IR Enable</i>	<i>Reserved</i>					

Field	Bits	Default	Description	
Reserved	7	0	Must write 0.	
IR Enable	6	1	0	Disabled
			1	Enabled ( <b>default</b> )
Reserved	5:0	00000	Must Write 00000.	

## OPTICAL SENSOR LTR-X221A

### ALS\_AGC\_CONTROL Register (0x90) (Read/Write)

The ALS\_AGC\_CONTROL register controls the automatic gain switching operation for ALS channel. The AGC mode can be enabled by writing 1 to ALS\_AGC\_EN bit. The switching thresholds can be configured through AGC\_HI\_LIMIT and AGC\_LO\_LIMIT respectively. In default settings, when ALS count exceeds the AGC\_HI\_LIMIT of 87.5%, the sensor will automatically switch the gain lower. In the other direction, when ALS count falls below AGC\_LO\_LIMIT of 500 counts, the sensor will automatically switch the gain higher. When AGC is enabled, the gain will be dynamically adjusted by sensor. Hence, the actual gain applied should be read out from ALS\_STATUS register bits[4:1] for application to lux conversion formula.

0x90	ALS_AGC_CONTROL (default = 0x0C)							
	Bit 7	Bit 6	Bit 5	Bit 4	Bit 3	Bit 2	Bit 1	Bit 0
	Reserved			ALS AGC Enable	AGC HI LIMIT		AGC LO LIMIT	

Field	Bits	Default	Description
Reserved	7:5	000	Must write 000.
ALS AGC Enable	4	0	0 <b>Disabled (default)</b>
			1 Enabled (default)
AGC HI LIMIT	3:2	11	Automatically switch gain lower when ALS count exceeds the specified percentage of full scale:
			00 50.0%
			01 62.5%
			10 75.0%
11 <b>87.5% (default)</b>			
AGC LO LIMIT	1:0	00	Automatically switch gain higher when ALS count falls below the specified percentage of full scale:
			00 <b>Fixed 500 counts (default)</b>
			01 12.5%
			10 25.0%
11 37.5%			

## OPTICAL SENSOR LTR-X221A

### ALS\_THRESHOLD Register (0x91-0x94) (Read/Write)

ALS\_THRES\_UPPER & ALS\_THRES\_LOWER registers are used to set the upper and lower limits of the threshold values for interrupt functions. Interrupt functions compare the values in the ALS\_THRESHOLD registers to the measured data value in ALS\_DATA registers.

Field	Bits	Default	Description	
ALS_THRES_UPPER_LSB	0x91	11111111	--	ALS upper interrupt threshold value, LSB
ALS_THRES_UPPER_MSB	0x92	11111111	--	ALS upper interrupt threshold value, MSB
ALS_THRES_LOWER_LSB	0x93	00000000	--	ALS lower interrupt threshold value, LSB
ALS_THRES_LOWER_MSB	0x94	00000000	--	ALS lower interrupt threshold value, MSB

### ALS\_CONFIG1 (0x95) (Read/Write)

The ALS\_CONFIG1 register must be set as 0x47.

0x95	ALS_CONFIG1 (default = 0x47)							
	Bit 7	Bit 6	Bit 5	Bit 4	Bit 3	Bit 2	Bit 1	Bit 0
	<i>Reserved</i>							

Field	Bits	Default	Description
Reserved	7:0	01000111	Must write 01000111.

## OPTICAL SENSOR LTR-X221A

### ALS\_CONTROL2 Register (0x98) (Read/Write)

Setting the Reset bit will reset the sensor into its default state.

IR Gain Select extends the gain range of IR channel by providing gain scaling down to 1/8. The effective gain for IR channel equals to the selected Divider multiplies with the selected ALS Gain in ALS\_CONTROL register.

ALS Single Mode Enable is used to control ALS integration when ALS is set into Single Mode operation in register ALS\_CONTROL register. Setting ALS Single Mode Enable bit will activate the ALS measurement once. The sensor will remain in Active Idle mode after completion of one ALS measurement.

0x98	ALS_CONTROL2 (default = 0x44)							
	Bit 7	Bit 6	Bit 5	Bit 4	Bit 3	Bit 2	Bit 1	Bit 0
	Reserved			IR Gain Select		Reserved	ALS Single Mode Enable	Reset

Field	Bits	Default	Description	
Reserved	7:5	010	Must write 000.	
IR Gain Select	4:3	00	Gain divider for IR channel	
			00	No divider ( <b>default</b> )
			01	Divide by 2
			10	Divide by 4
			11	Divide by 8
Reserved	2	1	Must write 1.	
ALS Single Mode Enable	1	0	Single mode control	
			0	Wait for Single Mode Trigger ( <b>default</b> )
			1	Run Single Mode once
Reset	0	0	0	No Action ( <b>default</b> )
			1	Reset registers to default values.

## OPTICAL SENSOR LTR-X221A

### INTERRUPT Register (0x99) (Read/Write)

INTERRUPT register controls the operation of the interrupt pin and functions. The INTERRUPT\_STATUS register is updated even if interrupt pin is INACTIVE / high-impedance state.

0x99	INTERRUPT (default = 0x00)							
	Bit 7	Bit 6	Bit 5	Bit 4	Bit 3	Bit 2	Bit 1	Bit 0
	Reserved						Interrupt Polarity	Interrupt Enable

Field	Bits	Default	Description	
Reserved	7:2	000000	Must write 000000.	
Interrupt Polarity	1	0	0	INT pin is active low ( <b>default</b> )
			1	INT pin is active high
Interrupt Enable	0	0	0	INT pin is INACTIVE / high impedance state ( <b>default</b> )
			1	ALS measurement can trigger INT pin state change

### INTERRUPT\_STATUS Register (0x9A) (Read Only)

INTERRUPT\_STATUS register stores information about ALS interrupt status. Reading ALS Interrupt will not clear the interrupt status. The interrupt status will be cleared when the data registers are read.

0x9A	INTERRUPT_STATUS (default = 0x00)							
	Bit 7	Bit 6	Bit 5	Bit 4	Bit 3	Bit 2	Bit 1	Bit 0
	Reserved							ALS Interrupt

Field	Bits	Default	Description	
Reserved	7:1	0000000	Reserved	
ALS Interrupt	0	0	Interrupt status	
			0	Interrupt signal Inactive ( <b>default</b> )
			1	Interrupt signal Active

## OPTICAL SENSOR LTR-X221A

### INTERRUPT\_PERSIST Register (0x9B) (Read/Write)

INTERRUPT\_PERSIST register sets the N number of times the measurement is out of the threshold range settings before asserting the INT (Interrupt) pin.

0x9B	INTERRUPT PERSIST (default = 0x00)							
	Bit 7	Bit 6	Bit 5	Bit 4	Bit 3	Bit 2	Bit 1	Bit 0
	Reserved				ALS PERSIST			

Field	Bits	Default	Description	
Reserved	7:4	0000	Must write 0000.	
ALS PERSIST	3:0	0000	0	Every ALS value out of threshold range ( <b>default</b> )
			1	2 consecutive ALS values out of threshold range
			.....	.....
			1111	16 consecutive ALS values out of threshold range

### PART\_ID Register (0x9D) (Read Only)

The PART\_ID register defines the part number of the sensor.

0x9D	PART_ID (default = 0xB0)							
	Bit 7	Bit 6	Bit 5	Bit 4	Bit 3	Bit 2	Bit 1	Bit 0
	Part ID							

### MANUFAC\_ID Register (0x9E) (Read Only)

The MANUFAC\_ID register defines the manufacturer identification of the sensor.

0x9E	MANUFAC_ID (default = 0x05)							
	Bit 7	Bit 6	Bit 5	Bit 4	Bit 3	Bit 2	Bit 1	Bit 0
	Manufacturer ID							

## OPTICAL SENSOR LTR-X221A

### ALS\_CONFIG4 (0xC9) (Read/Write)

The ALS\_CONFIG4 register must be set as 0x3E.

0xC9	ALS_CONFIG4 (default = 0x06)							
	Bit 7	Bit 6	Bit 5	Bit 4	Bit 3	Bit 2	Bit 1	Bit 0
	<i>Reserved</i>							

Field	Bits	Default	Description
Reserved	7:0	00000110	Must write 00111110.

### ALS\_CONFIG5 (0xCA) (Read/Write)

The ALS\_CONFIG5 register must be set as 0x0E.

0xCA	ALS_CONFIG5 (default = 0x06)							
	Bit 7	Bit 6	Bit 5	Bit 4	Bit 3	Bit 2	Bit 1	Bit 0
	<i>Reserved</i>							

Field	Bits	Default	Description
Reserved	7:0	00000110	Must write 00001110.

### 7. Application Information

#### Lux Conversion Formula

$Lux_{Calculated}$  is the calculated lux reading based on the output ADC from ALS DATA.

$$Lux_{Calculated} = \frac{Lux_{Factor} * ALS_{Data}}{Gain_{Fac} * \frac{\{INT_{Scale} * (INT_{Steps} + 1)\}}{100}} * Window\ Factor$$

$Lux_{Factor} = 0.533$

Integration time = INT Scale X INT Steps (in millisecond)

INT Scale = 0x81 bit<3:2>

INT Steps = 0x82 bit<7:0>

Where :

1. For device under tinted window with coated-ink of flat transmission rate at 400-600nm wavelength, window factor WFAC is to compensate light loss due to the lower transmission rate from the coated-ink.
  - a. WFAC = 1 for NO window / clear window glass.
  - b. WFAC >1 device under tinted window glass. Calibrate under white LED.
2. The Gain factors:

ALS Gain	X1	X2	X4	X8	X16	X32	X64	X128	X256	X512	X1024
Gain	1	2	4	8	16	32	64	128	256	512	1024

Table 11 Gain Factors for Lux Conversion



Operating Mode

**Standby Mode**

The device is by default in stand-by mode after power-up. No measurement activity in the sensor in this mode. I2C communication is allowed to be able to read from/write to the registers.

**Active Continuous Mode**

The ALS can be set in active continuous mode. Measurement data is expected to be available within a known fixed time. Refer to wakeup time and integration time from specification/registers sections.

**Single Mode**

In single mode, IC performs a single ALS measurement and returns to active idle state after measurement is completed. Figure below shows the measurement state diagram for Single Mode.

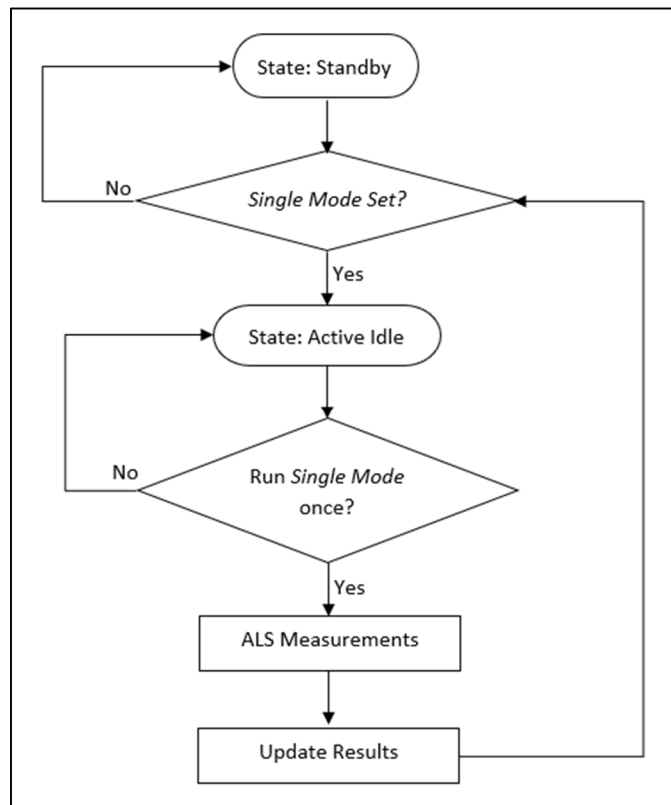

Figure 20 Single Mode Measurement State Diagram

### Interrupt Features

The ALS interrupt pin (INT) is enabled by Bit[0] (Interrupt Enable) of INTERRUPT register. The interrupt is set when the ALS data is above the upper threshold (ALS\_THRES\_UPPER) or below the lower threshold (ALS\_THRES\_LOWER) for a specified number of consecutive measurements set in INTERRUPT\_PERSIST register.

Flow diagram below illustrates the operation flow in Active Continuous Mode and the use of thresholds and interrupt.

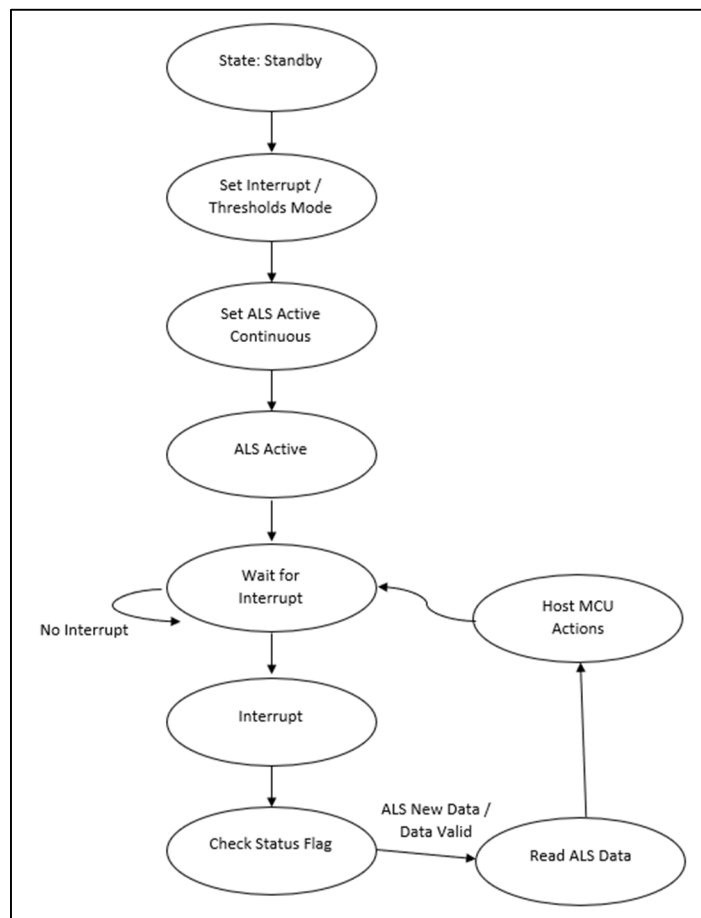

Figure 21 ALS Interrupt Flow Diagram

8. Recommended Lead-Free Reflow Profile

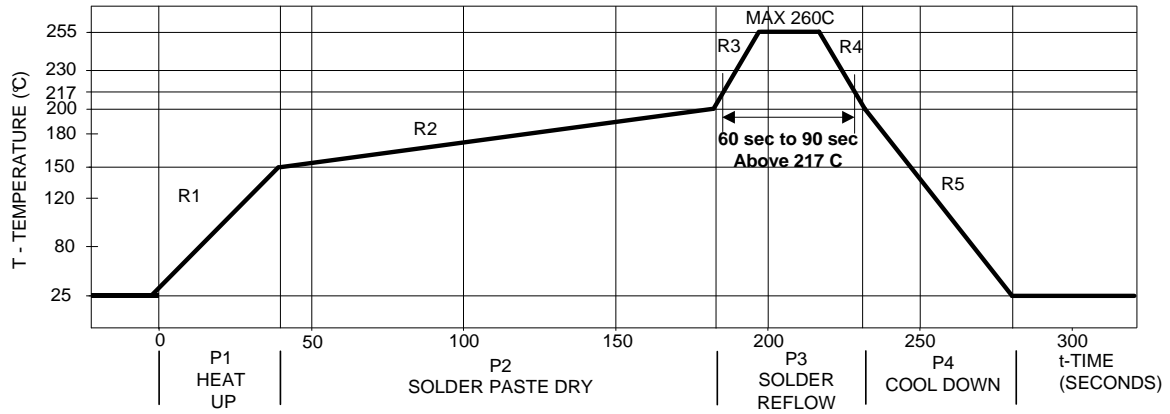

Figure 22 Reflow Profile

Process Zone	Symbol	$\Delta T$	Maximum $\Delta T/\Delta time$ or Duration
Heat Up	P1, R1	25°C to 150°C	3°C/s
Solder Paste Dry	P2, R2	150°C to 200°C	100s to 180s
Solder Reflow	P3, R3	200°C to 260°C	3°C/s
	P3, R4	260°C to 200°C	-6°C/s
Cool Down	P4, R5	200°C to 25°C	-6°C/s
Time maintained above liquidus point , 217°C		> 217°C	60s to 90s
Peak Temperature		260°C	-
Time within 5°C of actual Peak Temperature		> 255°C	20s
Time 25°C to Peak Temperature		25°C to 260°C	8mins

Table 12 Reflow Profile Details

It is recommended to perform reflow soldering no more than twice.

### 9. Moisture Proof Packaging

All devices are shipped in moisture proof package. Once opened, moisture absorption begins. This part is compliant to JEDEC J-STD-033A Level 3.

#### Shelf Life

Device has the shelf life of 12 months if stored in an unopened moisture proof package. It is recommended to store in following condition.

- Shelf Life: 12 months
- Ambient Temperature: <40°C
- Relative Humidity: <90%

#### Floor Life

After removal from the moisture barrier bag, the parts should be stored at the recommended storage conditions and soldered within seven days.

- Floor Life: 168 hours
- Ambient Temperature: <30°C
- Relative Humidity: <60%

#### Re-Baking Information

When the moisture barrier bag is opened and the parts are exposed to the recommended storage conditions for more than seven days, the parts must be baked before re-flow to prevent damage to the parts.

Package	Temperature	Time
In Reels	60°C	48 hours
In Bulk	100°C	4 hours

*Table 13 Baking Conditions*

Baking should only be done once.

10. Recommended Land Pattern

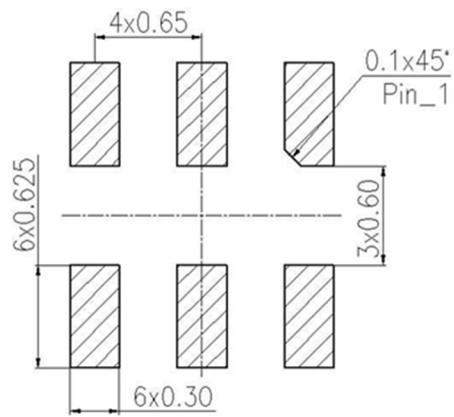

Figure 23 Recommended Land Pattern

Note: All dimensions are in millimeters.

## OPTICAL SENSOR LTR-X221A

### 11. Tape and Reel

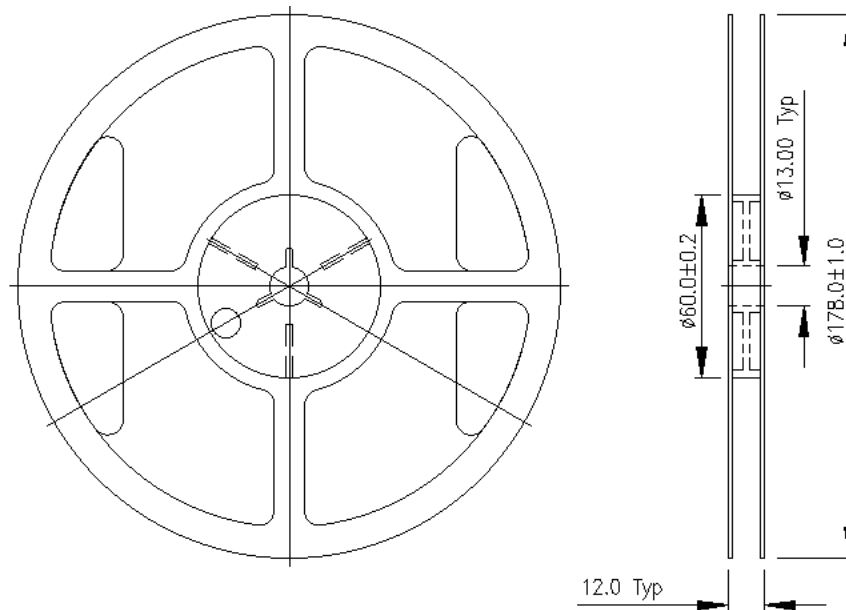
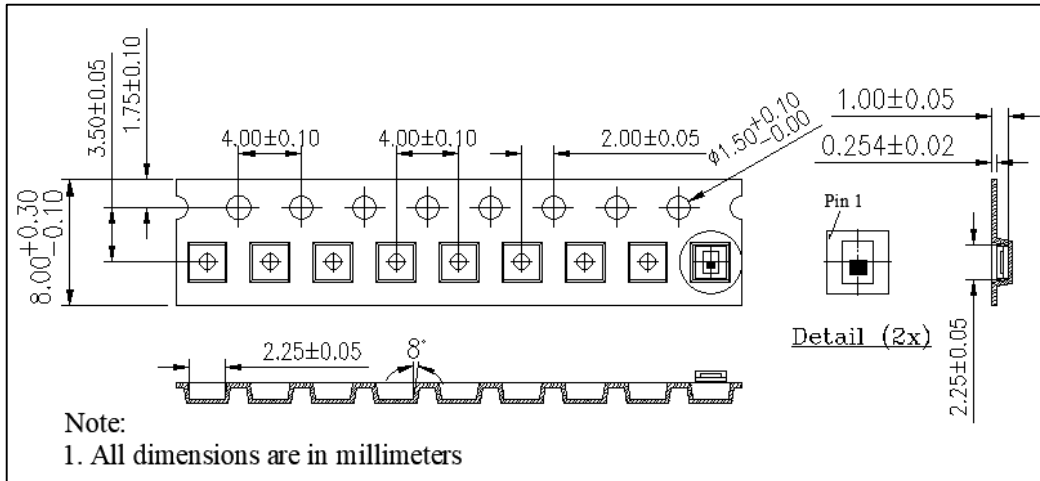

Figure 24 Tape and Reel Dimensions

Notes:

1. All dimensions are in millimeters (inches)
2. Empty component pockets sealed with top cover tape
3. 7 inch reel - 3500 pieces per reel
4. In accordance with ANSI/EIA 481-1-A-1994 specifications

## OPTICAL SENSOR LTR-X221A

### Revision Table:

Version	Update	Page	Date
1.0	Final datasheet as created	Total 37	23-Jun-2022
1.1	Update setting	17 & 30	06-Sep-2022
1.2	Updated package quantity	2	21-May-2024